



Ceramic Infrared Radiators

Contents

Contents	Page
Basic physics	3
Application examples	5
Products	
Panel radiators	
FSF series	6
FSR series	8
HFS series	10
HSR series	12
HTS series	14
SHTS series	16
Long panel radiators	
FSL series	18
Rod radiators	
HLS series	20
IRS series	22
SBM series	24
Screw radiators	
IOT/75 and IOT/90	26
IR systems	
BSH	28
EBF	30
REF	32
Connection and control accessories	34
Metal parts	36
Radiation distribution	38
Power adjustment	39
Performance	40
Planning guidelines	41
General information	42
Summary	43

Elstein Infrared Radiators Top quality infrared technology products ...millionfold proved

The company Elstein-Werk was established in Northeim 1950 as the only factory worldwide specialised in manufacturing ceramic infrared radiators. Even then infrared radiators have been developed on the basis of own patents and processes, whose design and quality have determined the state of the art standards to this day.

Through continuous pioneer work and further development of our products, technically and economically interesting fields of application have been and are still being developed for infrared heating.

Today Elstein infrared radiators solve all kinds of heating and drying tasks. Together with the proven modular systems, heating areas with a high power density and selective energy application can be realised in the material to be heated. The controllability of the heat output using modern digital temperature controllers and thyristor switching units ensures optimum use of energy and therefore helps to save operating costs and to protect the environment.

A wide range is available for the initial installation, modifications or for extending machines and plants, which is and can be adjusted to the needs of the heating tasks or the drying process.

This technical brochure provides information about possible uses of Elstein products. We will be pleased to advise you on how to solve your specific heating task.



Figure 1: The company Elstein-Werk in Northeim

Range	Wavelength
Microwave	100 μm
IR radiation	10 μm
Light	1 μm
UV radiation	0,1 μm

Figure 2: Wavelength ranges

Infrared radiation is the transmission of energy by electromagnetic waves. The spectrum of this radiation lies outside the light visible to the human eye (Figure 2) in the wavelength range of 0.7 μm to around 80 μm . The transmission of energy does not require a transport medium and is therefore also possible in a vacuum.

Infrared radiators are classified according to their wavelength maximum of the spectral radiant power into short, medium and long-wave radiators. In short-wave infrared radiators the maximum is less than 1.5 μm . Long-wave infrared radiators are those whose maximum lies above 3 μm . Between them are the medium-wave infrared radiators. Figure 3 shows the spectral power distribution of several typical radiators in these classes. In general, the higher the temperature of a radiator, the shorter the wavelength of the radiation.

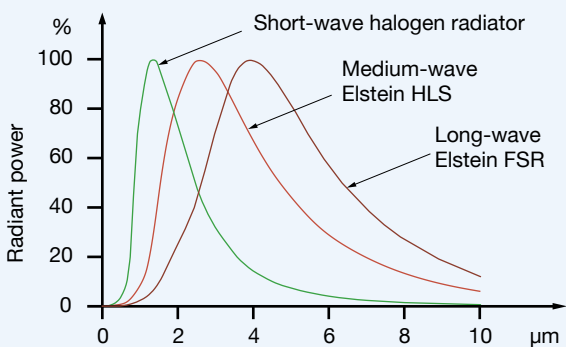

Figure 3: Spectral radiant power

The power emitted depends on the temperature of the radiator and its surface. Figure 4 shows the spectral power distribution of Elstein's SHTS and HTS infrared radiators at different surface temperatures. As you can see, at the same temperature, the black SHTS emits considerably more than the white HTS. However the positive influence of a black glaze does not become noticeable until temperatures above 800°C. Figure 4 also shows that, due to the radiation properties of the white glaze, the spectral radiant power of HTS radiator is virtually independent of the temperature.

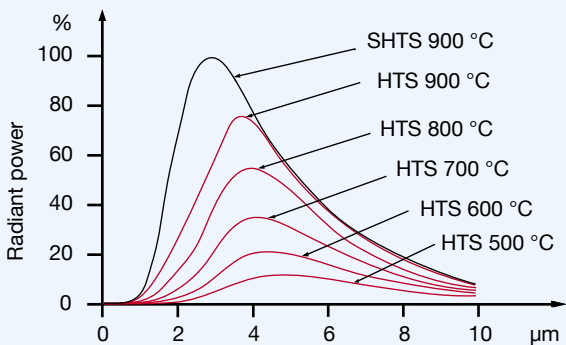

Figure 4: Spectral radiant power of Elstein radiators

The ideal radiator is the so-called black body. It absorbs and emits 100% radiation. In practice, all materials have lower radiation values, as they partly reflect the radiation or, as it is the case with glass, let it pass through. Figure 5, for example, shows the absorption of bright aluminium and ceramic. Aluminium only absorbs about 15%, the rest is reflected. Ceramic on the other hand absorbs about 90% of the radiation. As absorption and emission are based on the same physical causes in each body, it is clear that ceramic is ideally suited as a material for infrared radiators.

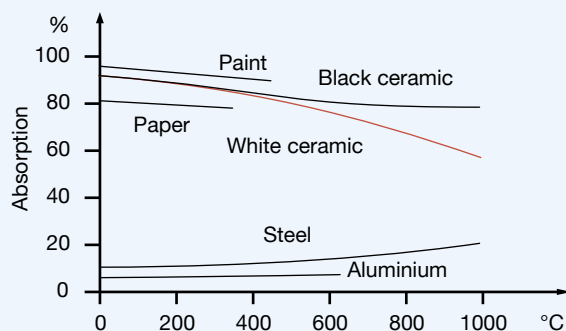
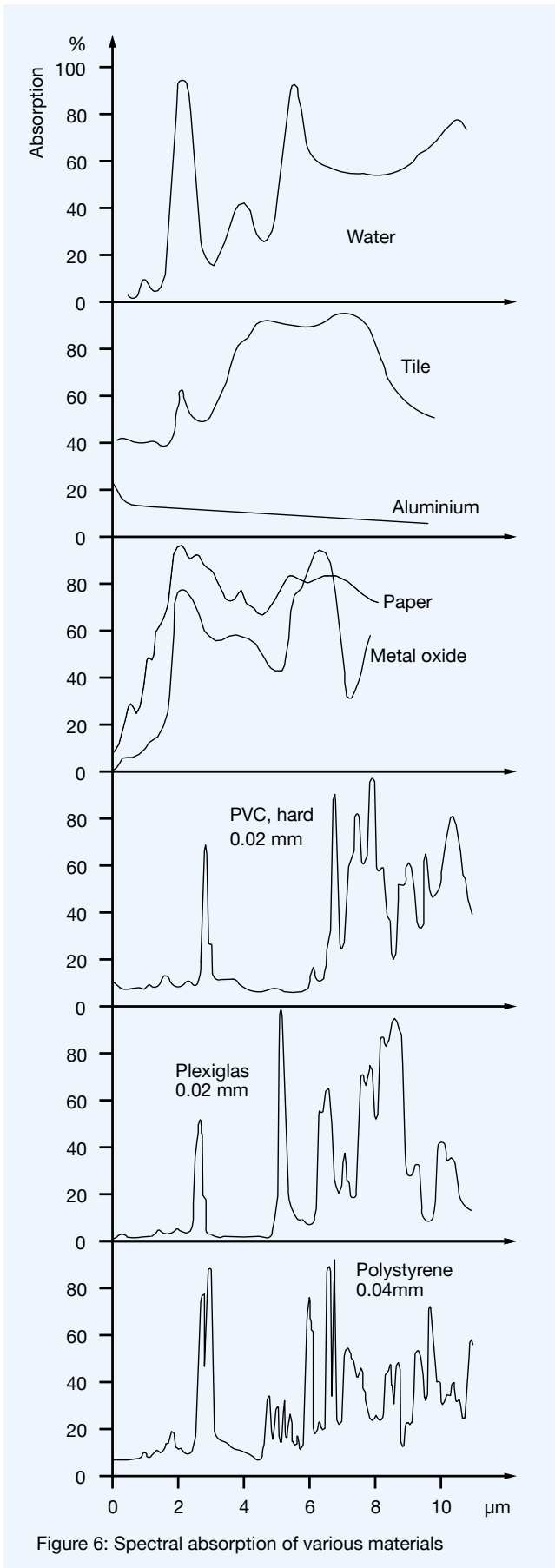

Figure 5: Absorption of various materials

The power emitted by a radiator roughly depends on the fourth power of the absolute temperature (cf. Figure 4). Therefore, infrared radiators are usually operated at temperatures from 300°C in order to achieve good efficiencies. In practice it must also be taken into consideration that the heated material also emits infrared radiation. Therefore, only the difference between the respective radiant powers actually heats the material.

Basic Physics



Apart from a few subtle differences, the absorption spectra of many materials in the medium and long-wave infrared range are very similar (Figure 6). While metal oxide and mineral materials absorb consistently well from around 3 μm , plastics with small layer thicknesses show characteristic absorption bands. In these wavelength ranges the absorption of energy is particularly favourable. Radiation in the other wavelength ranges is reflected or transmitted. This is significant when heating thin plastic foils, whereby the addition of small amounts of pigments can considerably improve the absorption properties. In practice, Elstein infrared radiators have proven to be particularly favourable for this application.

Elstein infrared radiators emit over a broad wavelength range. It is therefore not necessary to match the maximum absorption of the material to be heated with the emission maximum of the radiator. Whether the energy is absorbed by the material at a wavelength of 3 μm or at 6 μm is not important. Important is that the material to be heated has good absorption properties and the provision of the required heating power.

When bright or polished metals are heated on the other hand the absorption is hardly noticeable. The infrared radiation is primarily reflected. The reflectance is determined by the electrical conductivity and the surface quality of the metal. Slight changes in the surface property, e.g. greater roughnesses, oxide coats (cf. Figure 6) or paint layers, also enable heating by infrared radiation in these cases.

The use of infrared radiators for drying materials is particularly significant. As Figure 6 shows, water has a broad absorption spectrum in the medium to long-wave range. For this reason, drying and evaporation tasks can also be advantageously solved using Elstein infrared radiators.

Elstein infrared radiators ideally fulfil the various requirements of practical situations, and not only with respect to the high radiator emissivity but also the optimum wavelength range for heating appropriate for the material involved.

Application Examples

Application examples for the use of Elstein infrared radiators:

- Heating plastic foils and sheets in thermoforming machines
- Production of shrink foils and films
- Gelling PVC pasty coats on fabrics
- Heating GRP parts during production
- Thermofixation of nylon and perlon threads
- Activating glues and hot seal coats
- Drying plastic emulsions
- Heating laminated materials before punching
- Drying raw and printed papers, cardboards and wallpapers
- Drying skins, hides and paint sprayed leather
- Quick-drying gummed papers
- Drying and baking enamelled sheet metal parts
- Baking on powder coatings
- Drying glazes on ceramic tiles
- Tempering glass
- Drying washed glass
- Soldering printed circuit boards
- Pre-heating weld seams in pipe construction
- Baking on sound insulating mats
- Drying fireproof impregnations for illumination and decorative papers
- Heating climatic chambers
- Drying washed, dyed and dressed fabric
- Baking on fluidised bed coatings
- Drying glued wood or furniture pieces
- Heating the paper mash before it is squeezed
- Pre-heating plastic pipes for joining
- Curing epoxy resins
- Tempering injection mouldings
- Drying raw tobacco
- Heating dragée masses
- Baking and browning biscuits
- Heating icing or chocolate frosting
- Keeping meals warm
- Heating processed cheese
- Keeping outdoor switchgear cabinets dry
- Accelerating chemical conversions
- Therapeutic medical radiation
- Infrared heated cabins

This list could be continued ad infinitum. This is because almost all industrial production, handling or refining processes involve drying or heating tasks, and these can be solved outstandingly well using Elstein infrared radiators.

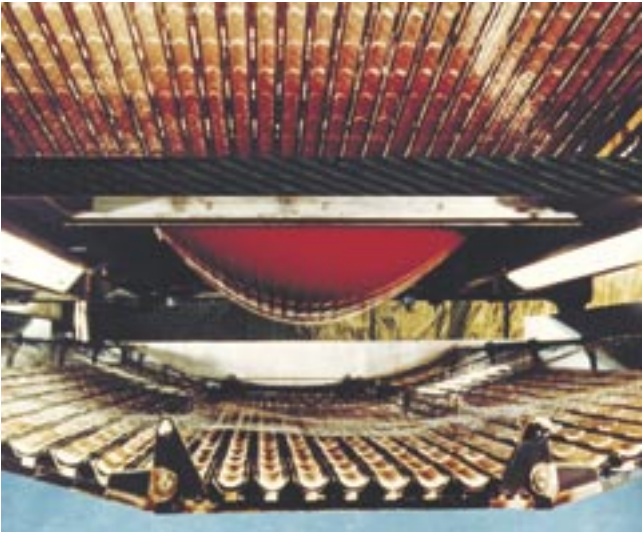

Figure 7: Thermoforming plant for boat hulls



Figure 8: 3-D heating panel for laminating door trims

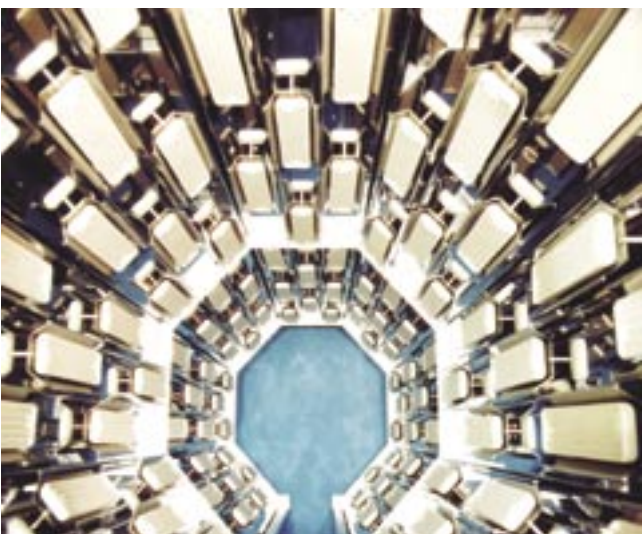

Figure 9: Paint dryer for electric motors



Figure 10: Elstein FSF series

Elstein FSF panel radiators, are ceramic infrared radiators with a low overall height. They are produced using a full-pour casting ceramic process and are designed for operating temperatures up to 750 °C and surface ratings up to 64 kW/m².

Compared to other Elstein panel radiators, the overall height of the FSF radiators, measured from the radiation surface up to the mounting plate, has been reduced by approximately 45%.

FSF series radiators can be used universally. The low overall height of the radiators enables space-saving installation, for example, which may be required to retrofit machines.

FSF radiators are available in four designs and cover the power range from 60 W to 1000 W.

Elstein FSF panel radiators have the customary market dimensions and can therefore be replaced with radiators with corresponding properties if the requirements change.

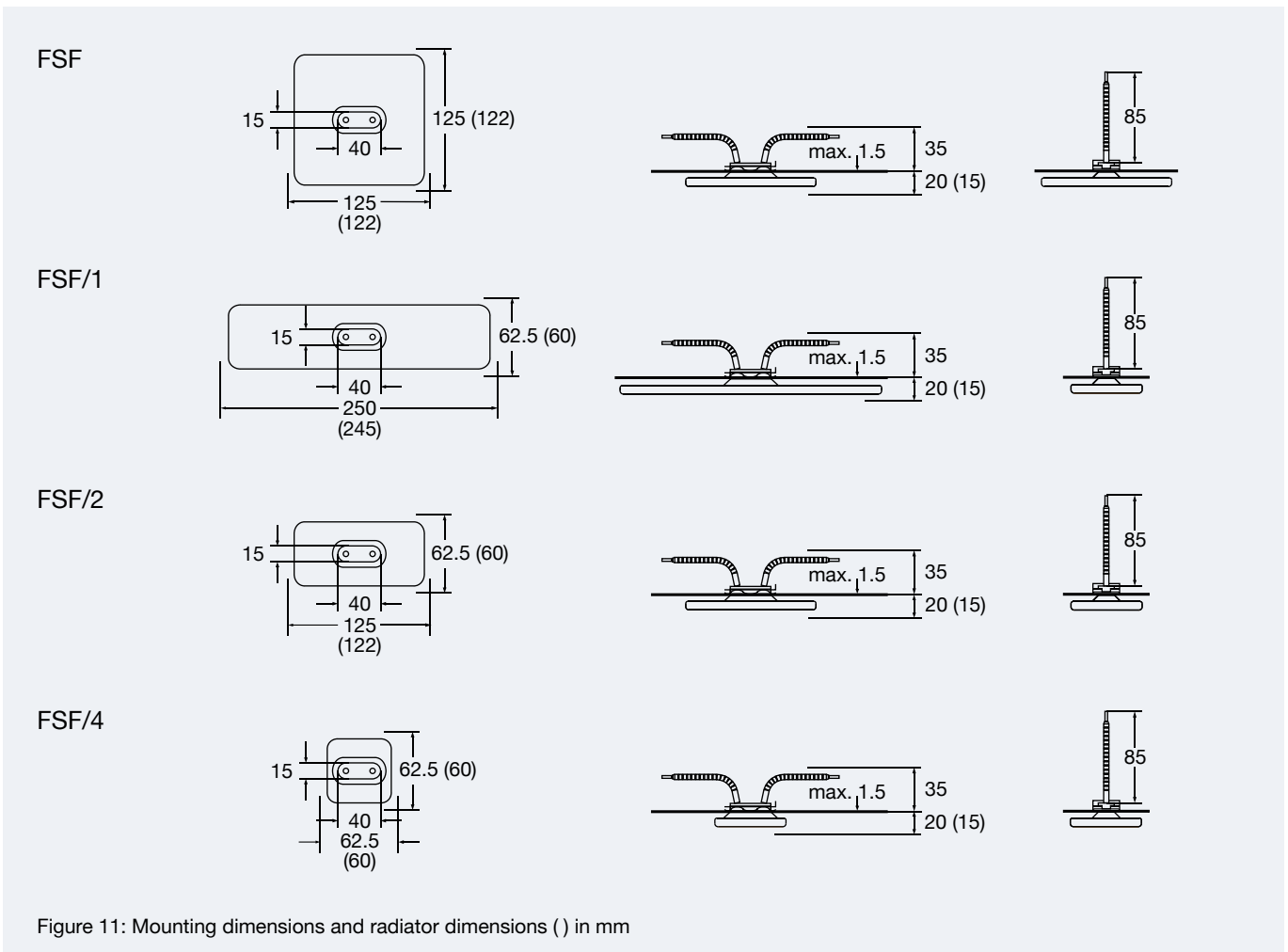
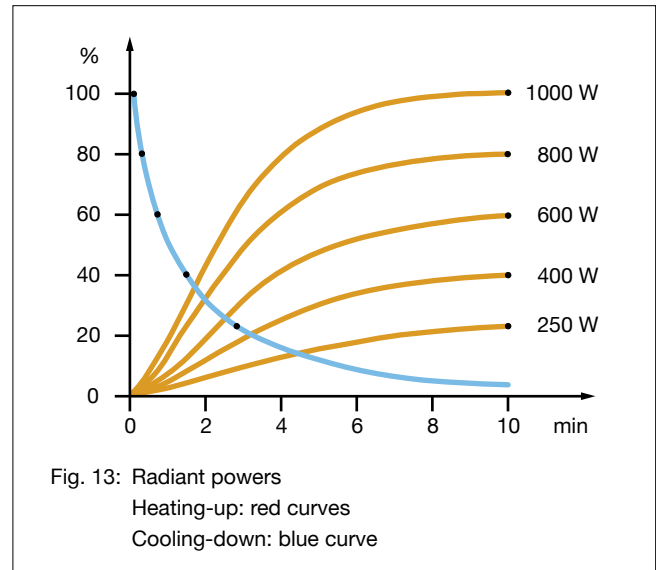
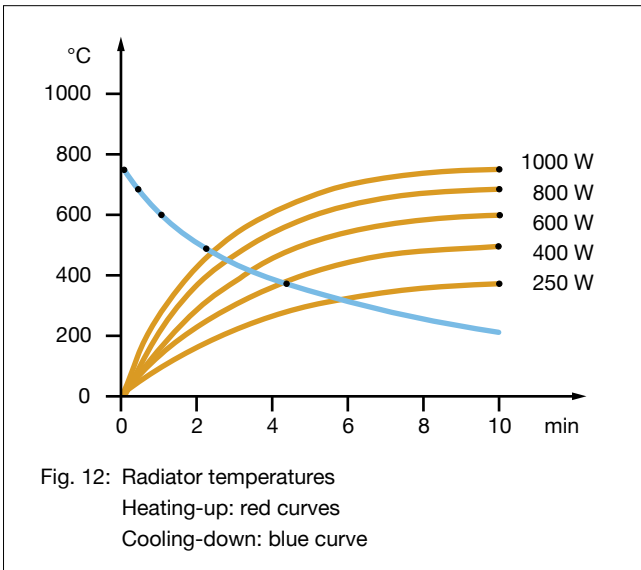

Figure 11: Mounting dimensions and radiator dimensions () in mm



Type, weight, wattage	FSF/1, FSF	220 g	250	400	600	800	1000	W
	FSF/2	125 g	125	200	300	400	500	W
	FSF/4	75 g	60	100	150	200	250	W
Surface rating			16.0	25.6	38.4	51.2	64.0	kW/m ²
Typical operating temperature			400	500	590	670	720	°C
Maximum permissible temperature			750	750	750	750	750	°C
Wavelength range			2 - 10					µm

Standard design	Thermocouple radiator	Variants
Operating voltage 230 V Ceramic full-pour casting Leads 85 mm Elstein standard socket Mounting set	Integrated thermocouple Type K (NiCr-Ni) Designation T-FSF, T-FSF/1, T-FSF/2, T-FSF/4 TC leads 100 mm	Special wattages Special voltages Extended leads Live leads with ring terminals

The power can be controlled using thermocouple radiators together with TRD temperature controllers, TSE thyristor switching units and other accessories.

IR radiation areas can be assembled using MBO mounting sheets.

The national safety regulations must be complied with for the respective application, for example, the IEC or EN standard 60519-1, Safety in electrical heating installations.

Further information and safety information are given in the mounting instruction enclosed with each radiator.



Figure 14: Elstein FSR series

Elstein FSR panel radiators are ceramic infrared radiators, which are designed for operating temperatures up to 750 °C. Surface ratings of up to 64 kW/m² can be installed.

FSR series radiators are made using a full-pour casting ceramic process and are characterised by their concave design. Due to the design of this type, there is a space between the radiator and mounting plate, which reduces the heat absorbed by the wiring space.

FSR panel radiators can be used universally and are suitable for assembling radiation areas with any geometry required. They are available in three designs and cover the power range from 60 W to 1000 W.

With its FSR panel radiators, the company Elstein-Werk has been setting design, type, power and quality standards, recognised worldwide since 1952, for ceramic infrared panel radiators.

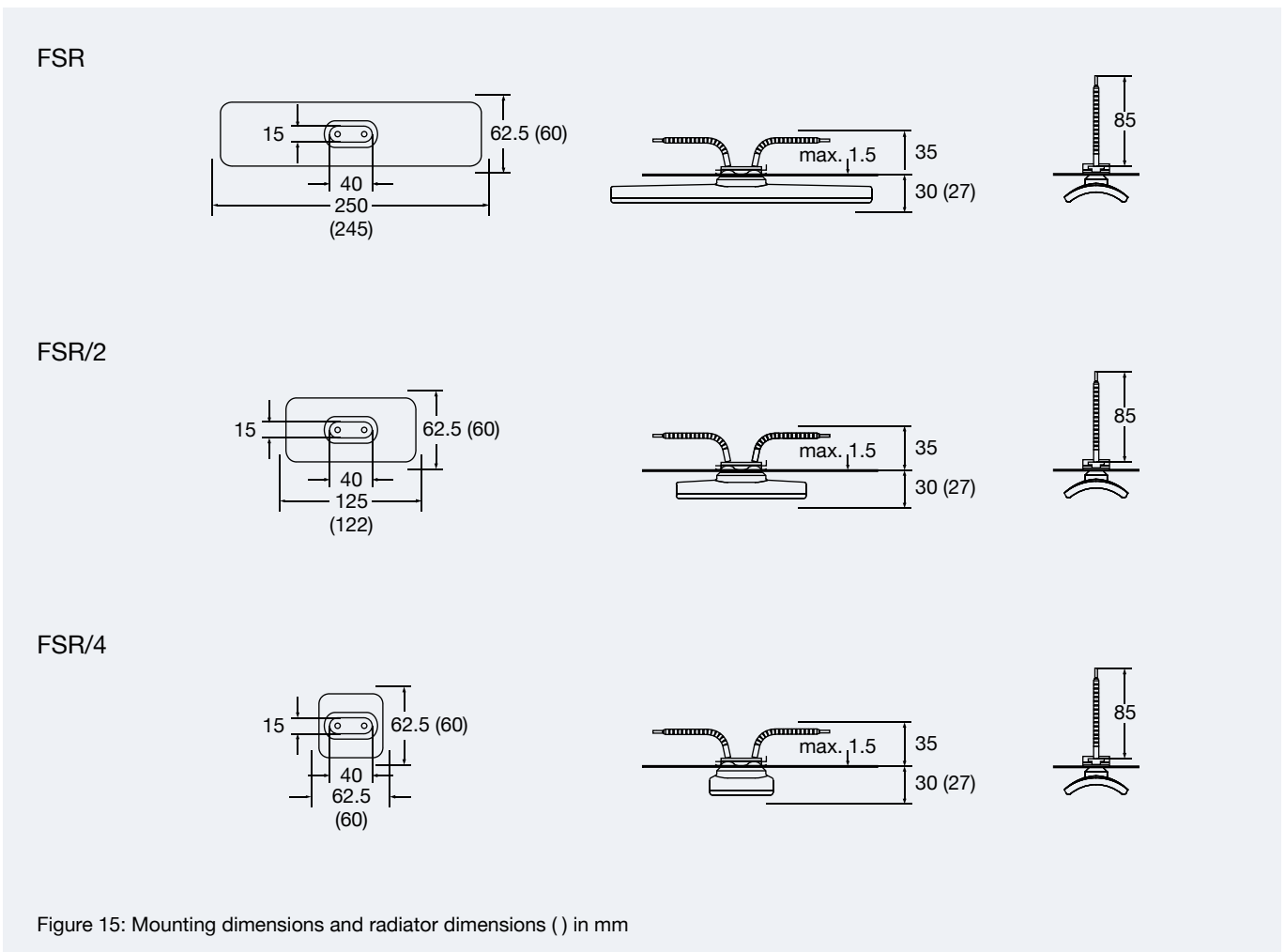

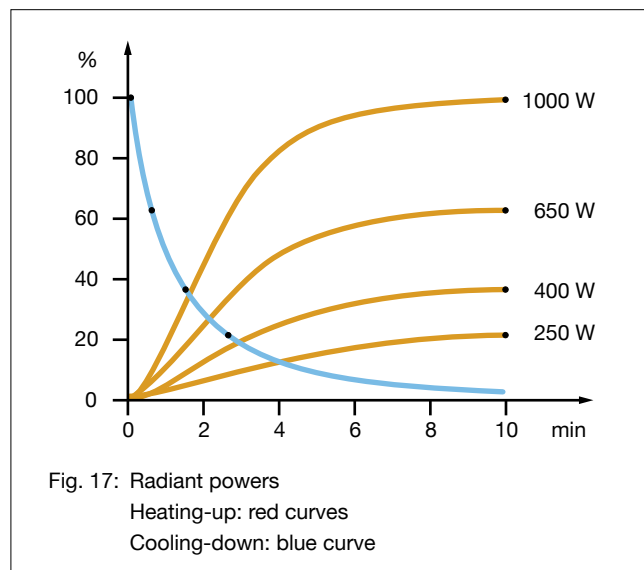
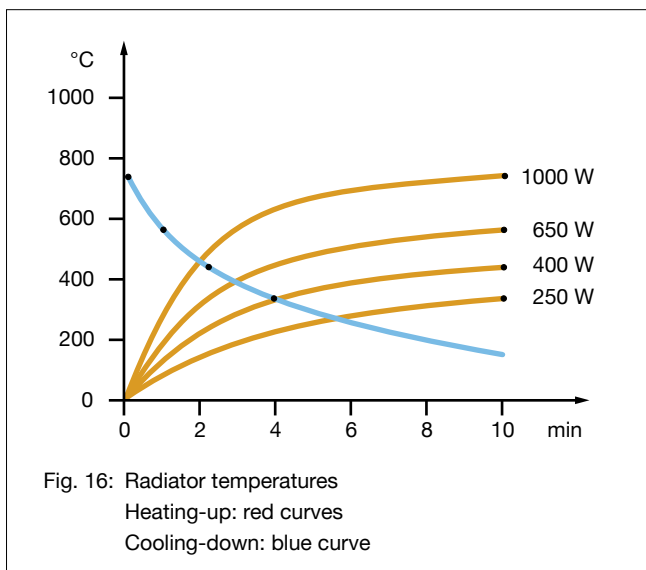

Type, weight, wattage	FSR	220 g	250	400	650	1000	W
	FSR/2	125 g	125	200	325	500	W
	FSR/4	75 g	60	100	200	250	W
Surface rating			16.0	25.6	41.6	64.0	kW/m ²
Typical operating temperature			400	500	620	720	°C
Maximum permissible temperature			750	750	750	750	°C
Wavelength range			2 - 10				μm

Standard design	Thermocouple radiators	Variants
Operating voltage 230 V Ceramic full-pour casting Leads 85 mm Elstein standard socket Mounting set	Integrated thermocouple Type K (NiCr-Ni) Designation T-FSR, T-FSR/2, T-FSR/4 TC leads 100 mm	Special wattages Special voltages Extended leads Live leads with ring terminals

The power can be controlled using thermocouple radiators together with TRD temperature controllers, TSE thyristor switching units and other accessories.

IR radiation areas can be assembled using REO reflectors, REF construction sets, EBF construction elements and MBO mounting sheets.

The national safety regulations must be complied with for the respective application, for example, the IEC or EN standard 60519-1, Safety in electrical heating installations.

Further information and safety information are given in the mounting instruction enclosed with each radiator.



Figure 18: Elstein HFS series

Elstein HFS panel radiators are ceramic infrared radiators, which are designed for medium surface ratings up to 38.4 kW/m² and operating temperatures up to 700 °C.

HFS series radiators are made using a hollow casting ceramic process. Compared to ceramic IR radiators produced using the full-pour casting process, HFS radiators have a considerably shorter heating-up time.

This technique was successfully used first for HFS radiators and then further developed for subsequent models.

HFS panel radiators are available in four designs and cover the power range from 60 W to 600 W.

Elstein HFS panel radiators have customary market dimensions and can therefore be replaced with radiators with the relevant properties if the requirements change.

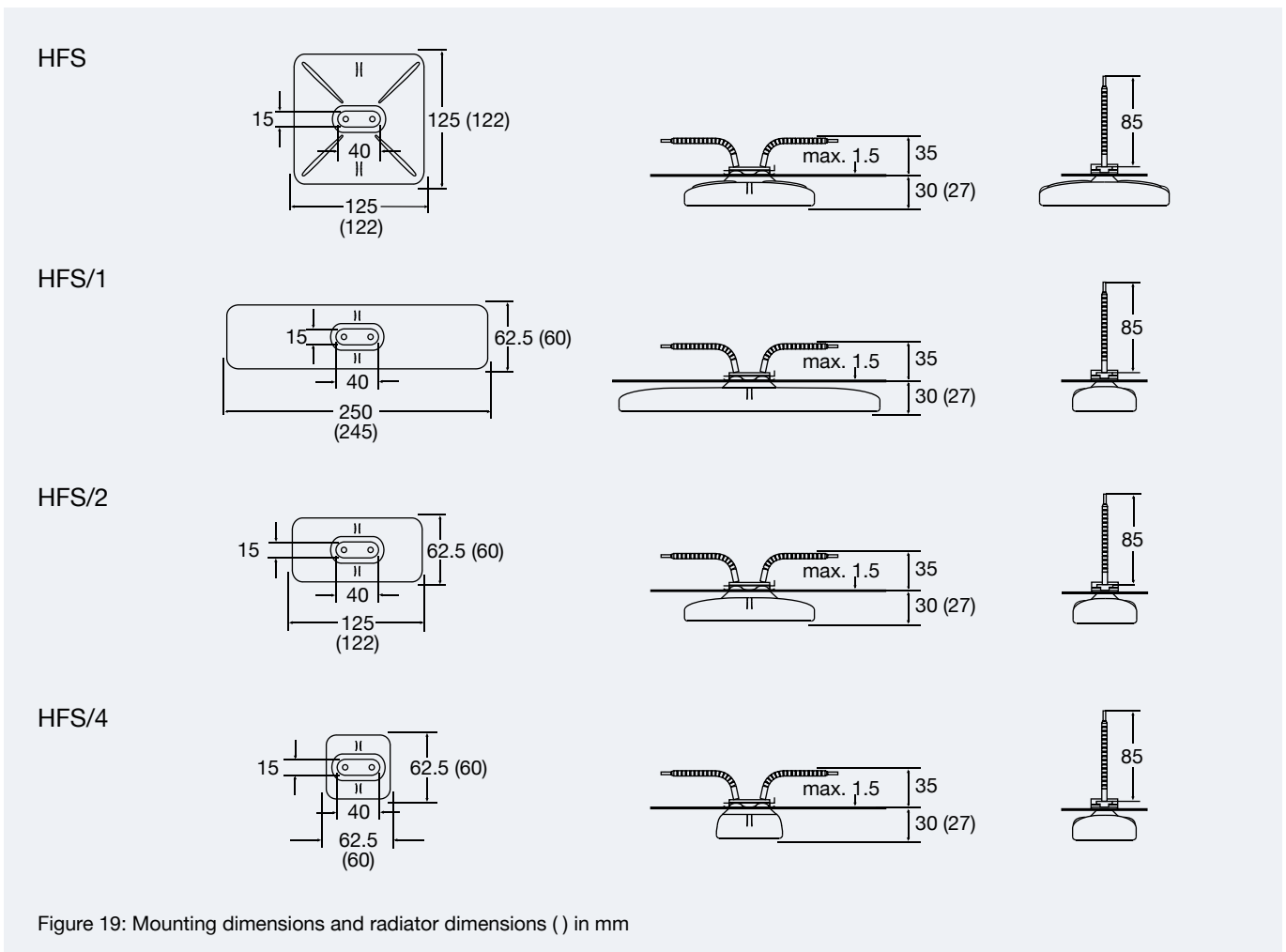
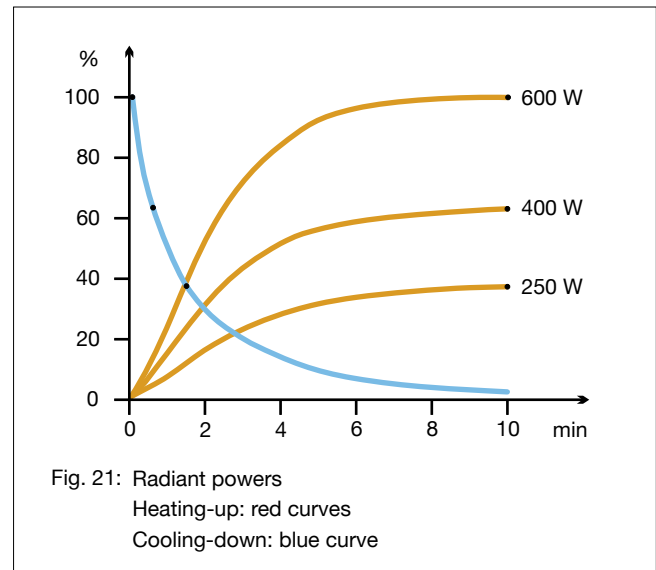
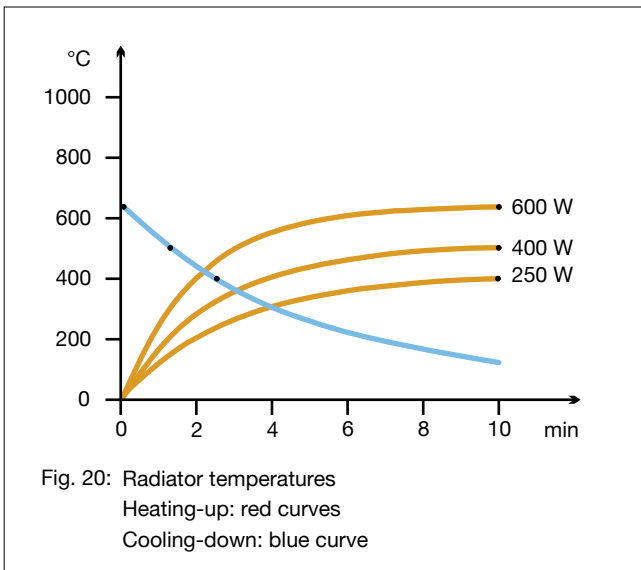

Figure 19: Mounting dimensions and radiator dimensions () in mm



Type, weight, wattage	HFS/1, HFS	220 g	250	400	600	W
	HFS/2	125 g	125	200	300	W
	HFS/4	75 g	60	100	150	W
Surface rating			16.0	25.6	38.4	kW/m ²
Typical operating temperature			420	510	630	°C
Maximum permissible temperature			700	700	700	°C
Wavelength range			2 - 10			μm

Standard design	Thermocouple radiators	Variants
Operating voltage 230 V Ceramic hollow casting Leads 85 mm Elstein standard socket Mounting set	Integrated thermocouple Type K (NiCr-Ni) Designation T-HFS, T-HFS/1, T-HFS/2, T-HFS/4 TC leads 100 mm	Special wattages Special voltages Extended leads Live leads with ring terminals

The power can be controlled using thermocouple radiators together with TRD temperature controllers, TSE thyristor switching units and other accessories.

IR radiation areas can be assembled using REO reflectors, REF construction sets and MBO mounting sheets.

The national safety regulations must be complied with for the respective application, for example, the IEC or EN standard 60519-1, Safety in electrical heating installations.

Further information and safety information are given in the mounting instruction enclosed with each radiator.



Figure 22: Elstein HSR series

Elstein HSR high speed radiators are quick-reaction ceramic infrared panel radiators, designed for operating temperatures up to 900 °C and surface ratings up to 64 kW/m².

The external characteristics of the HSR radiators is their visible heating coil, which is installed in a ceramic body. The heat released in the wiring space by this design is up to 65 % less compared to infrared radiators with a heating coil embedded in ceramic.

HSR high speed radiators are particularly suitable for use in clocked production processes, for frequent tool changes or if the temperature has to drop quickly in case of transfer disruptions, in order to prevent damage to the production plant.

Elstein HSR high speed radiators are available in three designs and cover the power range from 125 W to 1000 W.

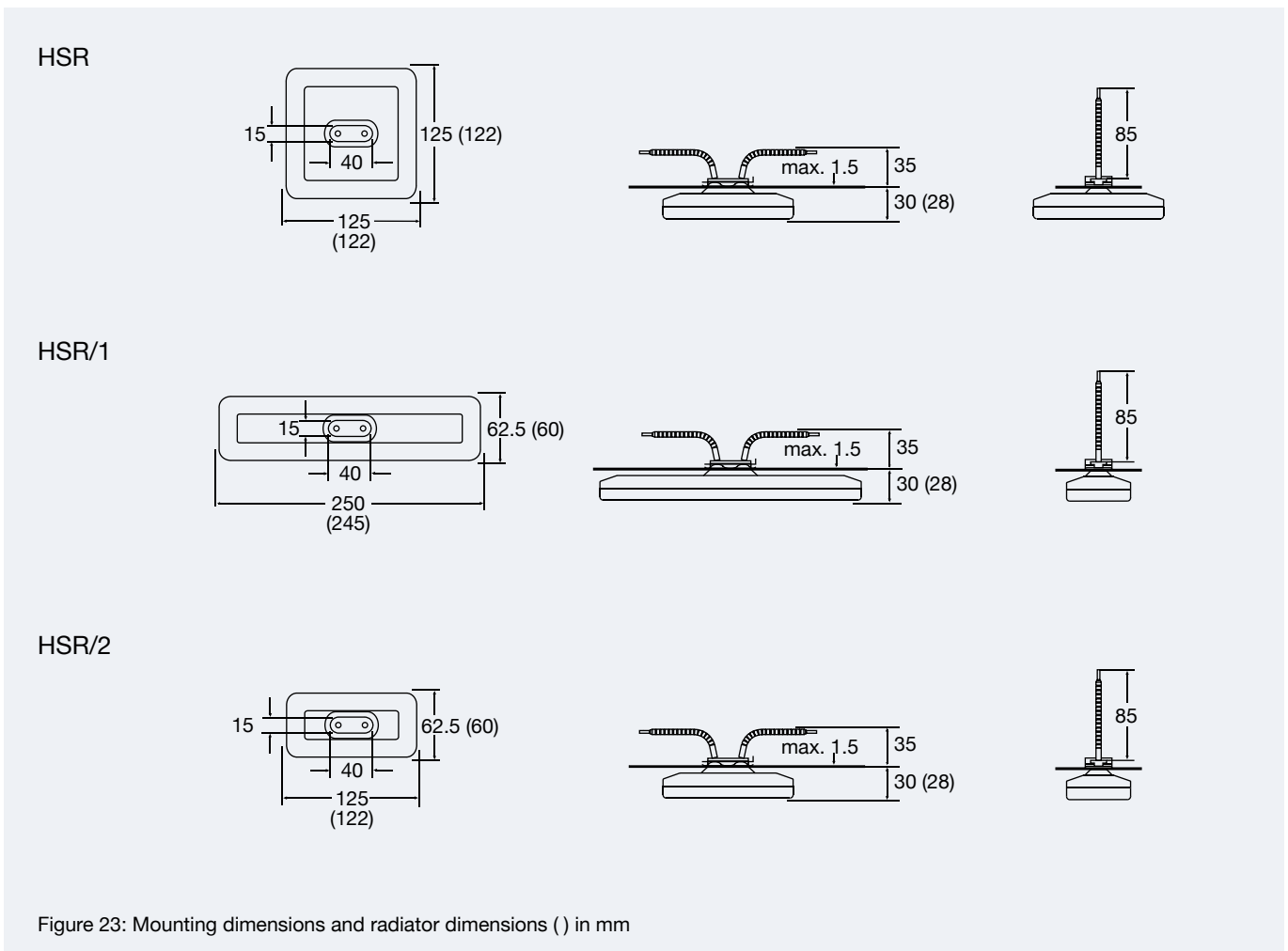

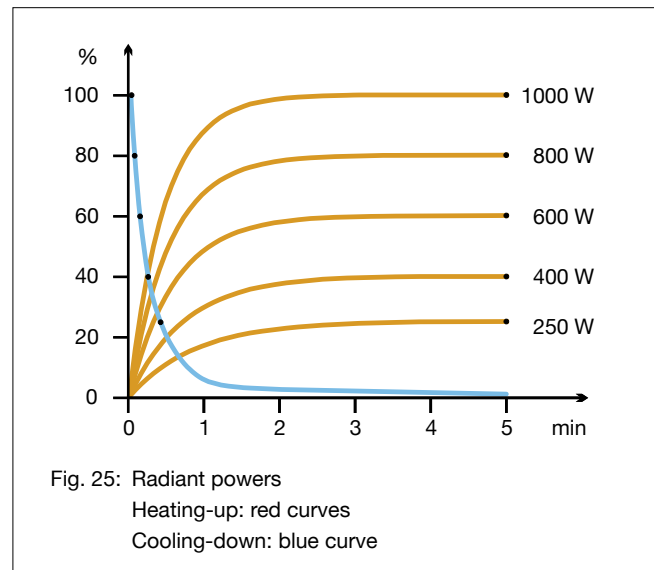
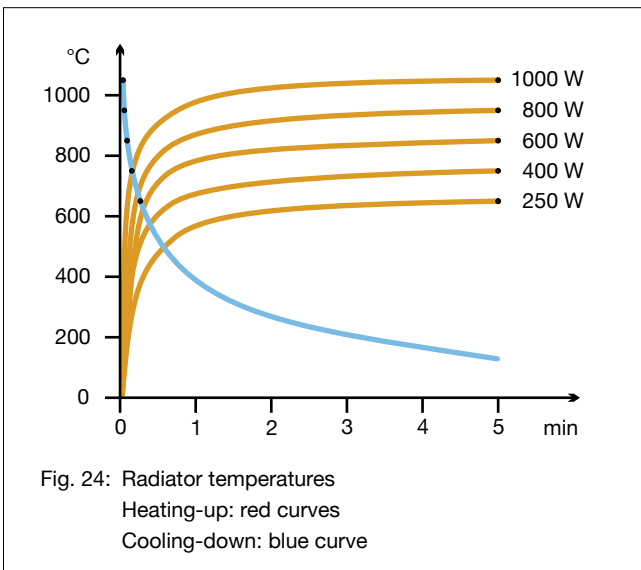

Type, weight, wattage	HSR	220 g	250	400	600	800	1000	W
	HSR/1	220 g	250	400	600	800	1000	W
	HSR/2	125 g	125	200	300	400	500	W
Surface rating			16.0	25.6	38.4	51.2	64.0	kW/m ²
Typical operating temperature			450	570	700	810	860	°C
Maximum permissible temperature			900	900	900	900	900	°C
Wavelength range			2 - 10					μm

Standard design	Thermocouple radiators	Variants
Operating voltage 230 V Ceramic moulding Leads 85 mm Elstein standard socket Mounting set Integrated thermal insulation	Not available. For means of controlling output see below.	Special wattages Special voltages Extended leads Live leads with ring terminals

The power can be adjusted using proprietary power controllers or by means of pyrometers with standard thermocouple signal output in conjunction with TRD temperature controllers.

IR radiation areas can be assembled using REO reflectors, REF construction sets, EBF construction elements, MBO mounting sheets and BSH construction panels.

The national safety regulations must be complied with for the respective application, for example, the IEC or EN standard 60519-1, Safety in electrical heating installations.

Further information and safety information are given in the mounting instruction enclosed with each radiator.



Figure 26: Elstein HTS series

Elstein HTS high temperature radiators are ceramic infrared panel radiators, which can be used for operating temperatures up to 900 °C and surface ratings up to 64 kW/m².

HTS series radiators are produced using a hollow-casting ceramic process and are filled with thermal insulation material. This improves the radiant power output to the material to be heated.

Furthermore, there is a significant reduction in heat dissipated in the wiring space, so that additional insulation of the heating area is usually not required.

Compared with IR radiators, which are produced using full-poured casting processes, HTS radiators have a considerably reduced heating-up time and, depending on the type of application, enable energy savings of up to 25 %.

Elstein HTS high temperature radiators are available in four designs and cover the power range from 60 W to 1000 W.

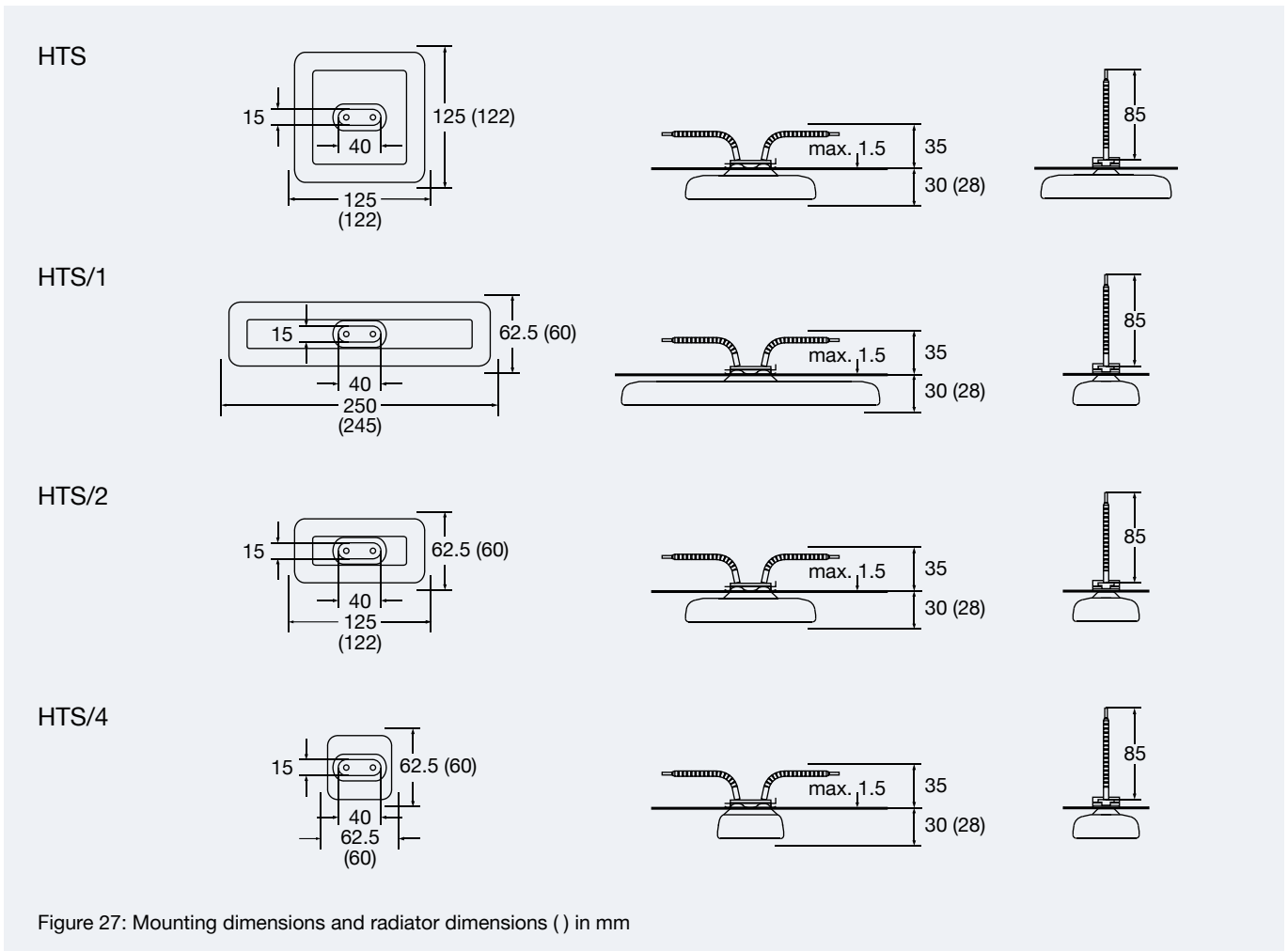
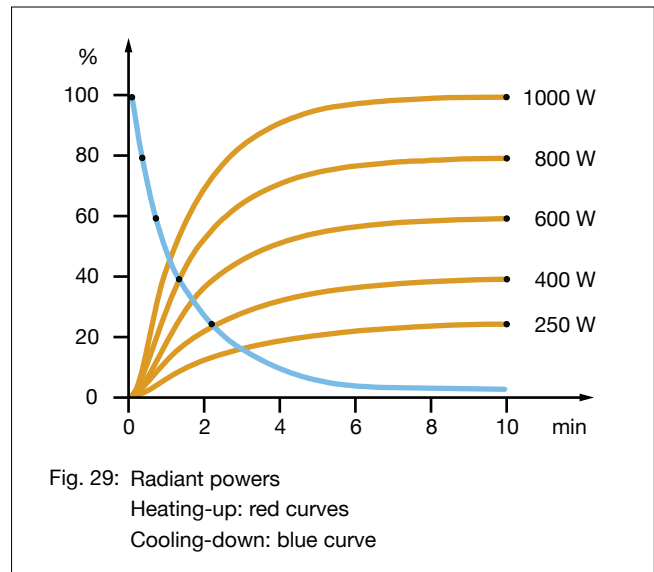
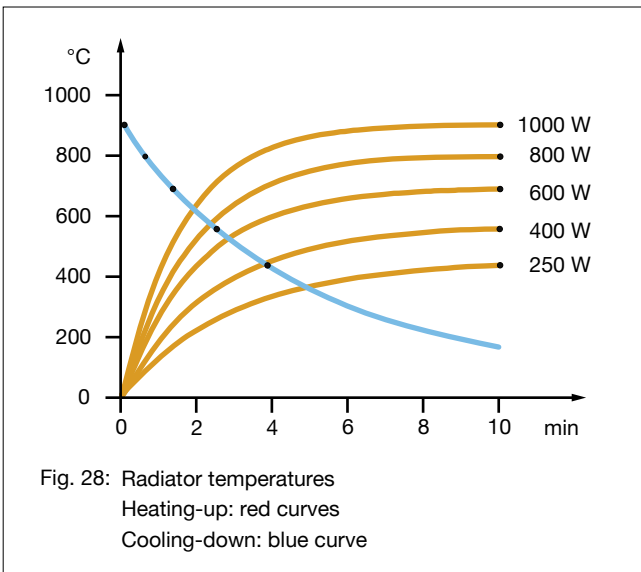

Figure 27: Mounting dimensions and radiator dimensions () in mm



Type, weight, wattage	HTS/1, HTS	220 g	250	400	600	800	1000	W
	HTS/2	125 g	125	200	300	400	500	W
	HTS/4	75 g	60	100	150	200	250	W
Surface rating			16.0	25.6	38.4	51.2	64.0	kW/m ²
Typical operating temperature			450	570	700	810	860	°C
Maximum permissible temperature			900	900	900	900	900	°C
Wavelength range			2 - 10					μm

Standard design	Thermocouple radiators	Variants
Operating voltage 230 V Ceramic hollow casting Leads 85 mm Elstein standard socket Mounting set Integrated thermal insulation	Integrated thermocouple Type K (NiCr-Ni) Designation T-HTS, T-HTS/1, T-HTS/2, T-HTS/4 TC leads 100 mm	Special wattages Special voltages Extended leads Live leads with ring terminals

The power can be controlled using thermocouple radiators together with TRD temperature controllers, TSE thyristor switching units and other accessories.

IR radiation areas can be assembled using REO reflectors, REF construction sets, EBF construction elements, MBO mounting sheets and BSH construction panels.

The national safety regulations must be complied with for the respective application, for example, the IEC or EN standard 60519-1, Safety in electrical heating installations.

Further information and safety information are given in the mounting instruction enclosed with each radiator.



Figure 30: Elstein SHTS series

Elstein SHTS super high temperature radiators were developed to increase the previous maximum possible surface rating of ceramic panel radiators from 64 kW/m² to 77 kW/m².

The SHTS radiators, produced using the hollow casting ceramic process, are filled with thermal insulation material and have a special black glaze and a gold-plated back. At an operating temperature of 900 °C, over 75 % of the electrical energy supplied is transferred to the material to be heated as medium to long-wave IR radiation.

SHTS series radiators are therefore particularly suitable for use in plant construction in which special solutions have to be drawn up for the customer's specific needs and for applications requiring high outputs.

The four designs cover the power range from 300 W to 1200 W and have customary market dimensions. Existing IR equipments can therefore be retrofitted with Elstein SHTS series radiators.

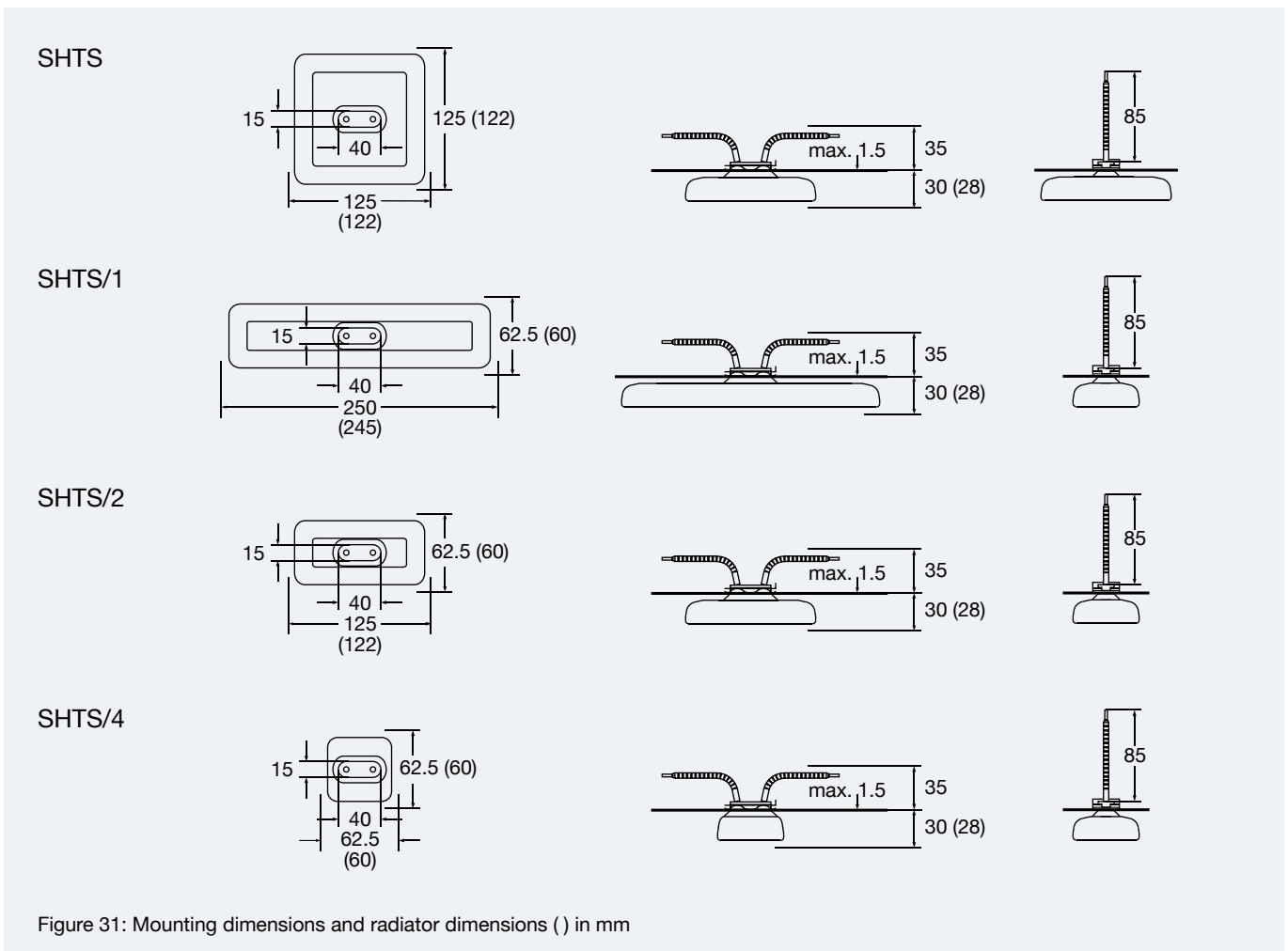
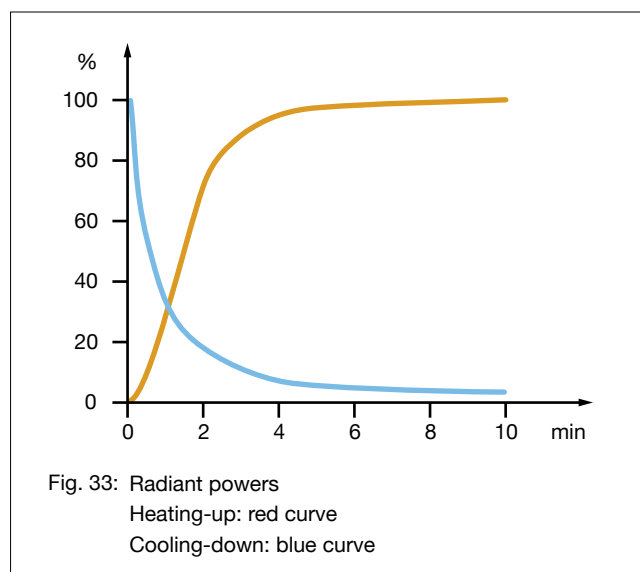
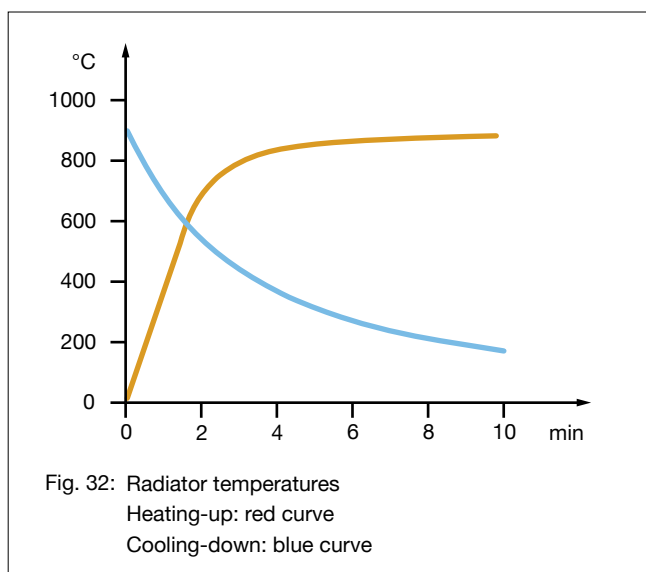

Figure 31: Mounting dimensions and radiator dimensions () in mm



Type, weight, wattage	SHTS/1, SHTS	220 g	1200	W
	SHTS/2	125 g	600	W
	SHTS/4	75 g	300	W
Surface rating			76.8	kW/m ²
Typical operating temperature			860	°C
Maximum permissible temperature			900	°C
Wavelength range			2 - 10	µm

Standard design	Thermocouple radiators	Variants
Operating voltage 230 V Ceramic hollow casting Leads 85 mm Elstein standard socket Mounting set Integrated thermal insulation Special black glaze Gold-plated back	Integrated thermocouple Type K (NiCr-Ni) Designation T-SHTS, T-SHTS/2, T-SHTS/2, T-SHTS/4 TC leads 100 mm	Special wattages Special voltages Extended leads Live leads with ring terminals

The power can be controlled using thermocouple radiators together with TRD temperature controllers, TSE thyristor switching units and other accessories.

IR radiation areas can be assembled using REO reflectors, REF construction sets, EBF construction elements and MBO mounting sheets.

The national safety regulations must be complied with for the respective application, for example, the IEC or EN standard 60519-1, Safety in electrical heating installations.

Further information and safety information are given in the mounting instruction enclosed with each radiator.



Figure 34: Elstein FSL series

Elstein FSL long panel radiators are ceramic infrared radiators with a low overall height, designed for operating temperatures up to 700 °C and surface ratings up to 45 kW/m².

They have two sockets with integrated twisted litz fixing wires, so that FSL radiators are easy to install and are space-saving. No special pre-punched holders or reflector plates are required for the assembly.

FSL series radiators are particularly suitable for lamellar heating tasks due to their long narrow design.

An example for lamellar heating tasks can be found in the lamp industry where FSL radiators are used for curing the coating of fluorescent tubes.

Elstein FSL long panel radiators are available in two designs with 300 W and 600 W.

FSL

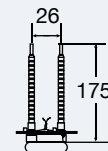
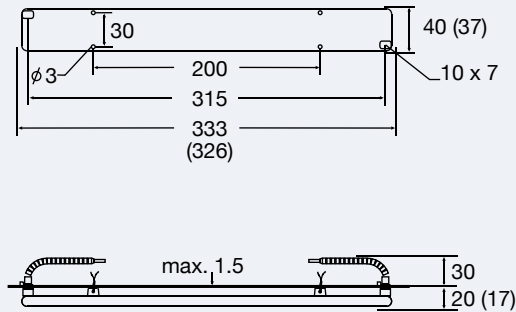

FSL/2

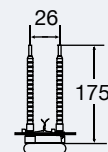
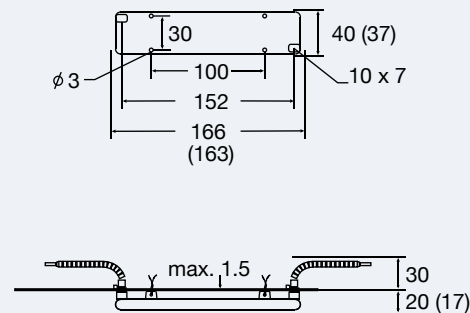
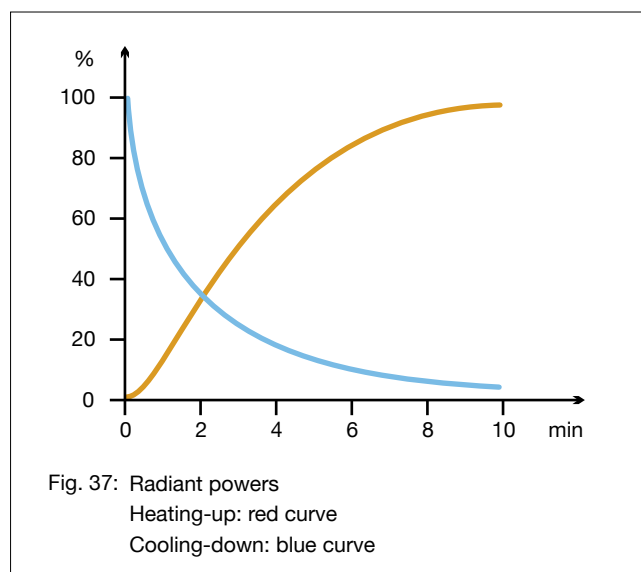
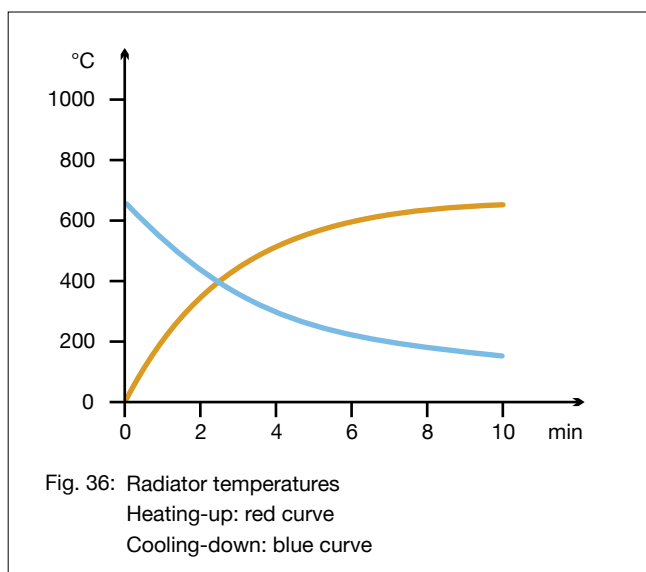

Figure 35: Mounting dimensions and radiator dimensions () in mm



Type, weight, wattage	FSL	220 g	600	W
	FSL/2	130 g	300	W
Surface rating			45.0	kW/m ²
Typical operating temperature			550	°C
Maximum permissible temperature			700	°C
Wavelength range			2 - 10	μm

Standard design	Thermocouple radiators	Variants
Operating voltage 230 V Ceramic full-pour casting Leads 175 mm Two litz mountings	Integrated thermocouple Type K (NiCr-Ni) Designation T-FSL, T-FSL/2 TC leads 110 mm	Special wattages Special voltages Extended leads Live leads with ring terminals

The power can be controlled using thermocouple radiators together with TRD temperature controllers, TSE thyristor switching units and other accessories.

The national safety regulations must be complied with for the respective application, for example, the IEC or EN standard 60519-1, Safety in electrical heating installations.

Further information and safety information are given in the mounting instruction enclosed with each radiator.

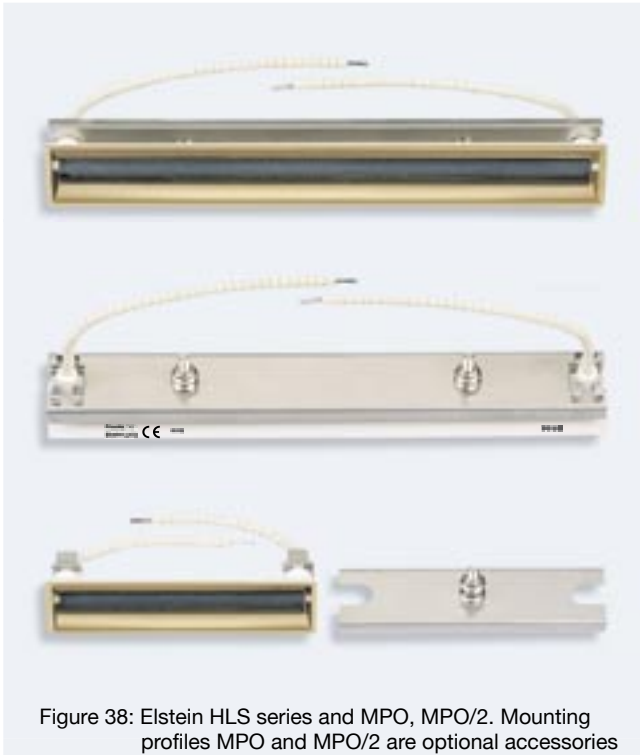

Figure 38: Elstein HLS series and MPO, MPO/2. Mounting profiles MPO and MPO/2 are optional accessories

Elstein HLS high performance radiators are ceramic infrared rod radiators, which can be used for operating temperatures up to 1000 °C and surface ratings up to 87 kW/m².

HLS series radiators have a gold-plated ceramic parabolic reflector and transfer up to 80% of the energy supplied as infrared radiation to the material to be heated.

In this way, HLS radiators allow material temperatures of up to 700 °C or high throughput speeds. The typical operating temperature of 1000 °C is reached in less than one minute.

HLS series radiators are therefore particularly suitable for use in plant construction in which special solutions have to be drawn up for the customer's specific needs and for applications requiring high outputs.

Elstein HLS high performance radiators are available in two designs with 750 W / 230 V and for pairwise serial connection with 375 W / 115 V.

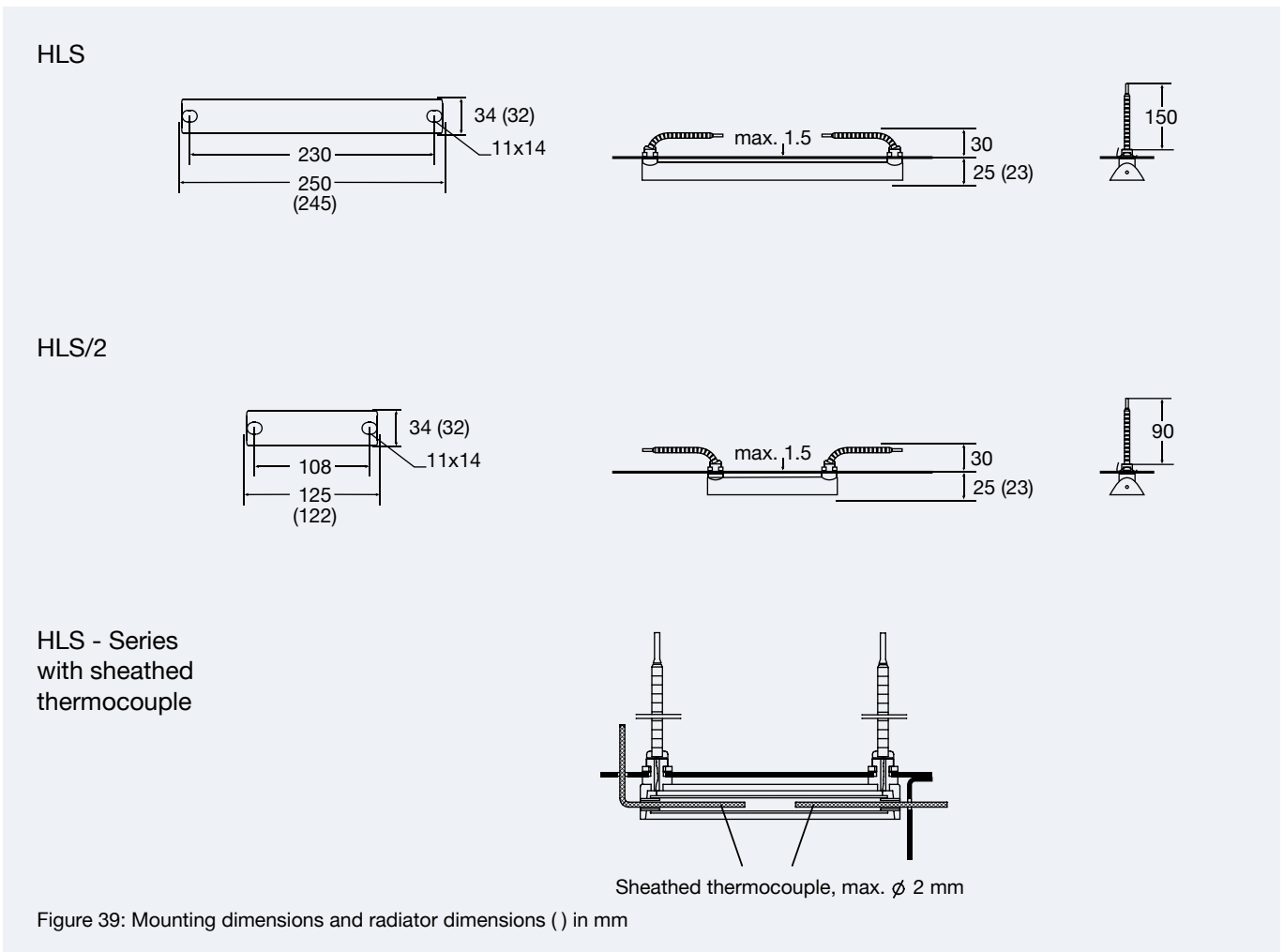

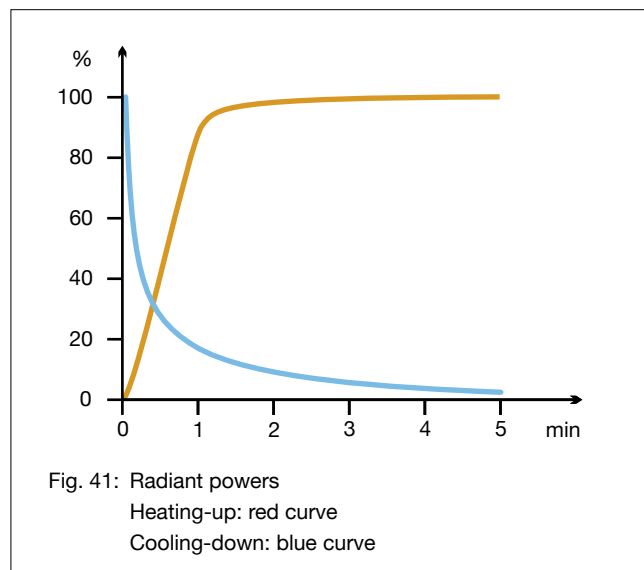
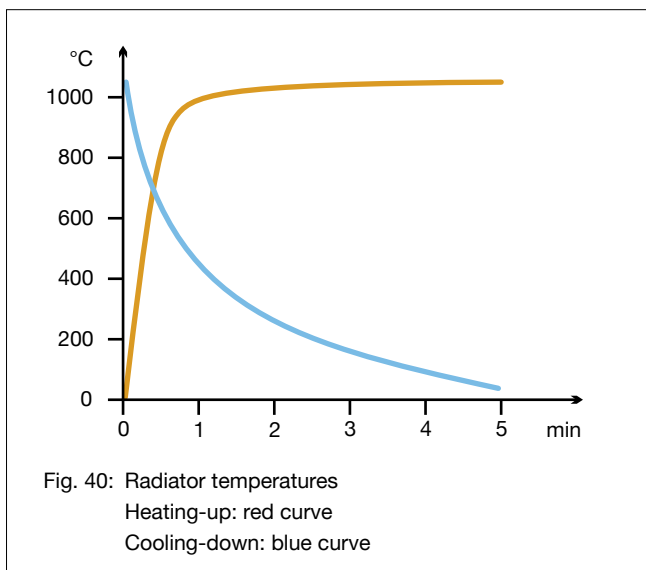

Type, weight, wattage	HLS	120 g	750	W
	HLS/2	60 g	325	W
Surface rating			87.0	kW/m ²
Typical operating temperature			1000	°C
Maximum permissible temperature			1100	°C
Wavelength range			2 - 10	μm

Standard design	Thermocouple radiators	Variants
HLS operating voltage 230 V HLS/2 operating voltage 115 V HLS leads 150 mm HLS/2 leads 90 mm Parabolic reflector gold-plated on the inside	Not available. For means of controlling output see below.	Special wattages Special voltages Extended leads Live leads with ring terminals

The power can be controlled using proprietary Type S sheathed thermocouples (Pt-PtRh) in conjunction with TRD temperature controllers, TSE thyristor switching units and further accessories. The sheathed thermocouples are pushed into the side (cf. Figure 39). They are not included in Elstein's range of products and therefore, if required, must be procured by the user.

IR radiation areas can be assembled using MPO mounting profiles.

The national safety regulations must be complied with for the respective application, for example, the IEC or EN standard 60519-1, Safety in electrical heating installations.

Further information and safety information are given in the mounting instruction enclosed with each radiator.



Figure 42: Elstein IRS series

Elstein IRS rod radiators are ceramic infrared radiators, designed for operating temperatures of up to 750 °C. With the help of MPO and MPO/2 mounting profiles, surface ratings of up to 72.0 kW/m² can be realised.

IRS series radiators have one mounting socket on each side, with which they can be fixed to a mounting profile with fixing springs.

The rod shaped design makes IRS radiators preferably suitable for linear heating tasks.

An example for linear heating tasks can be found in the timber industry, where IRS rod radiators are used to pre-heat edge strips.

Elstein IRS rod radiators are available in two designs and cover the power range from 200 W to 600 W.

IRS

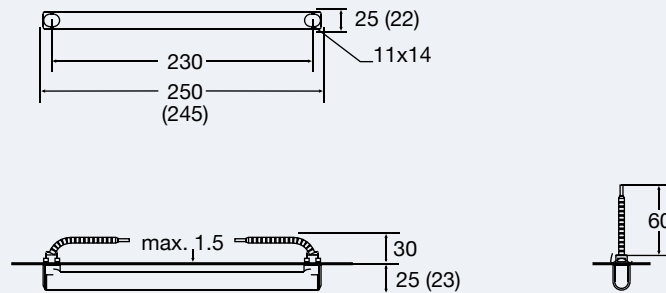

IRS/2

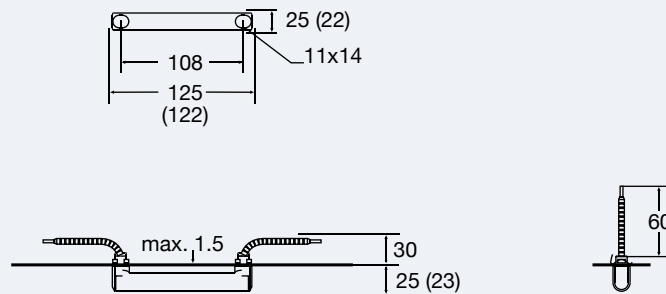
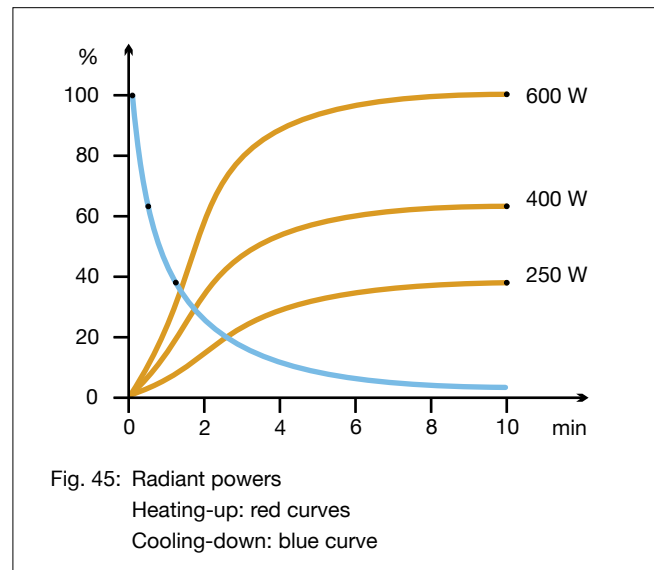
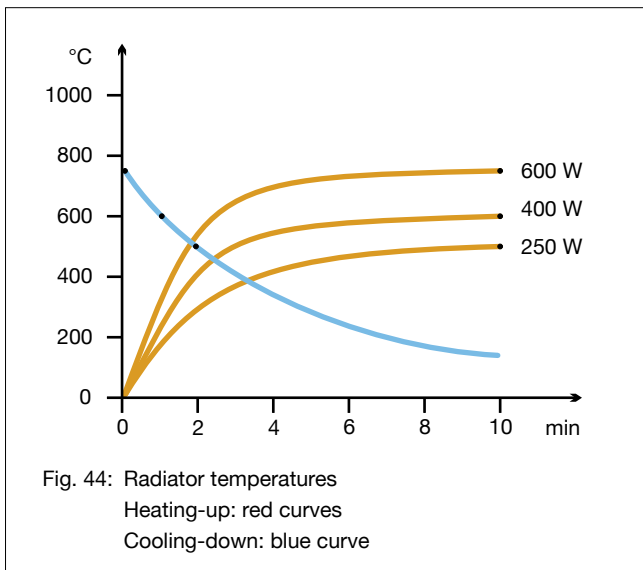

Figure 43: Mounting dimensions and radiator dimensions () in mm



Type, weight, wattage	IRS	95 g	400	600	W
	IRS/2	50 g	200	300	W
Surface rating			48.0	72.0	kW/m ²
Typical operating temperature			550	650	°C
Maximum permissible temperature			750	750	°C
Wavelength range			2 - 10		μm

Standard design Operating voltage 230 V Leads 60 mm Two mounting sockets Two fixing springs	Thermocouple radiators Integrated thermocouple Type K (NiCr-Ni) Designation T-IRS, T-IRS/2 TC leads 100 mm	Variants Special wattages Special voltages Extended leads Live leads with ring terminals
--	---	---

The power can be controlled using thermocouple radiators together with TRD temperature controllers, TSE thyristor switching units and other accessories.

IR radiation areas can be assembled using MPO mounting profiles.

The national safety regulations must be complied with for the respective application, for example, the IEC or EN standard 60519-1, Safety in electrical heating installations.

Further information and safety information are given in the mounting instruction enclosed with each radiator.



Figure 46: Elstein SBM series

Elstein SBM rod radiators are dark ceramic infrared radiators with surface ratings of up to 36.0 kW/m².

SBM radiators have been developed for use in infrared heated cabins and due to their long-wave infrared radiation gently and pleasantly heat the human body.

Furthermore, SBM rod radiators can also be used for other heating tasks. Due to their long oval design, they are particularly suitable for linear heating or for space-saving installations, if low installed heights have to be achieved.

SBM series radiators can be installed in any position. The power can be adjusted using a proprietary dimmer.

Elstein SBM rod radiators are available in two designs and cover the power range from 200 W to 400 W.

SBM/300

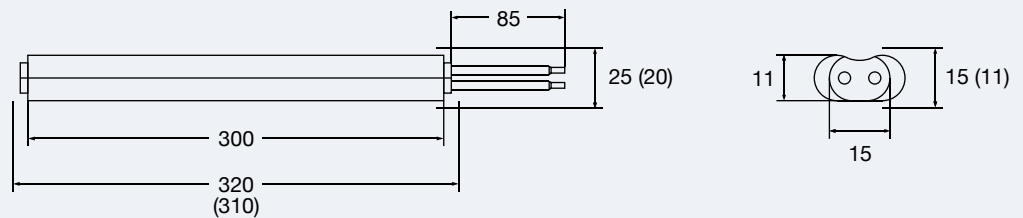

SBM/450

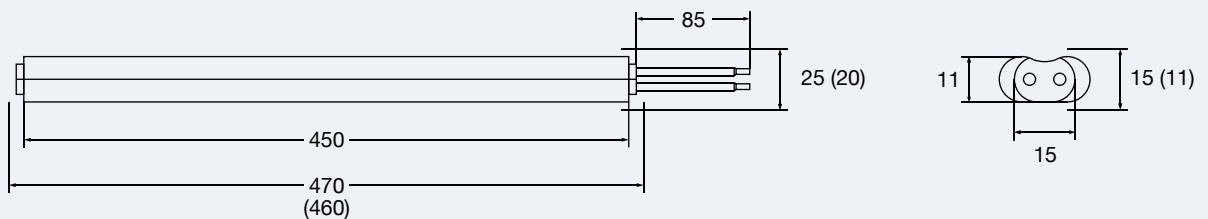
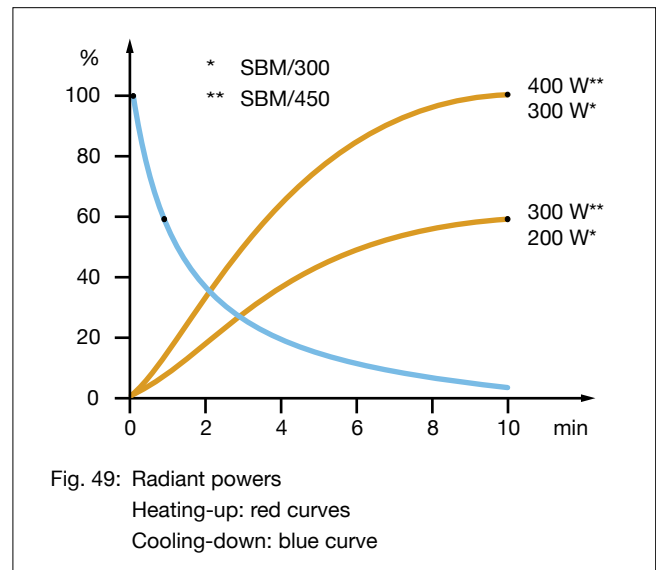
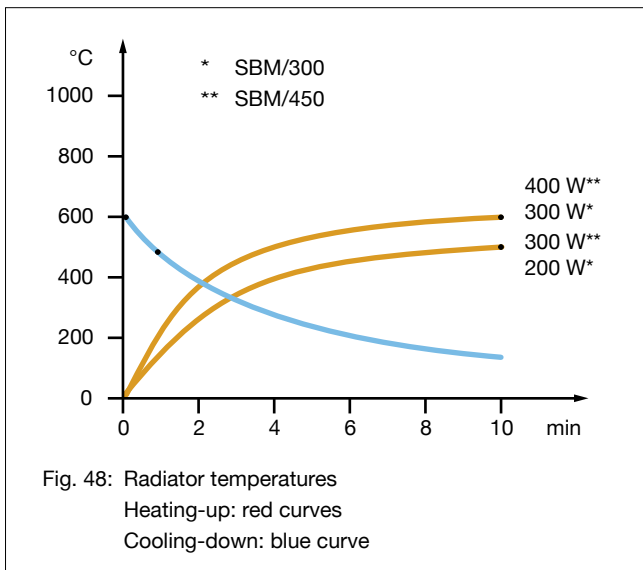

Figure 47: Mounting dimensions and radiator dimensions () in mm



Type, weight, wattage	SBM/300	110 g	200	300	-	-	W
	SBM/450	165 g	-	-	300	400	W
Surface rating			24.0	36.0	24.0	32.0	kW/m ²
Typical operating temperature			420	550	350	500	°C
Maximum permissible temperature			600	600	600	600	°C
Wavelength range			3 - 10				µm

Standard design Operating voltage 230 V Ceramic full-pour casting Length of the leads 85 mm	Thermocouple radiators Not available. For means of controlling output see below.	Variants Special wattages Special voltages Extended leads Live leads with ring terminals
---	---	---

The power can be adjusted using proprietary power controllers or dimmers.

The national safety regulations must be complied with for the respective application, for example, the IEC or EN standard 60519-1, Safety in electrical heating installations.

Further information is given in the safety information enclosed with each radiator.

Ceramic Infrared Screw Radiators



Figure 50: Elstein IOT/75 and IOT/90

Elstein IOT/75 and IOT/90 radiators are ceramic infrared dark radiators with E27 screw caps.

The standardised E27 thread allows easy and safe installation, as the radiators can be screwed in like bulbs into porcelain or metal sockets with porcelain insert.

Due to their simple connection, IOT/75 and IOT/90 infrared radiators are suitable both for individual operation and for configuring groups of radiators. They have diverse applications, in particular they range over terrariums/pets and livestock, breeding, medical and catering technology.

The power can be adjusted using a proprietary dimmer.

Elstein IOT/75 and IOT/90 radiators are available in two power levels of 60 W and 100 W or rather 150 W and 250 W.

IOT/75

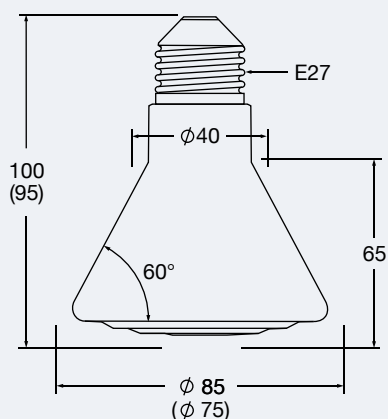

IOT/90

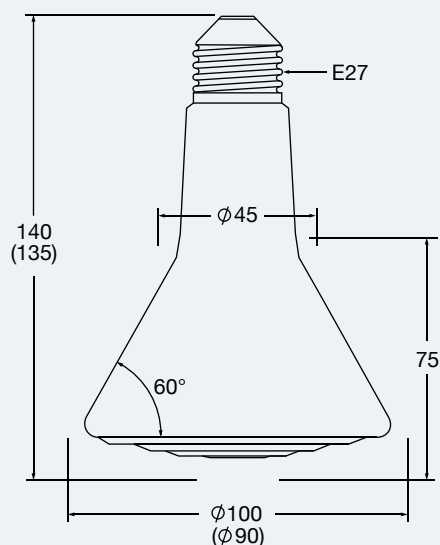
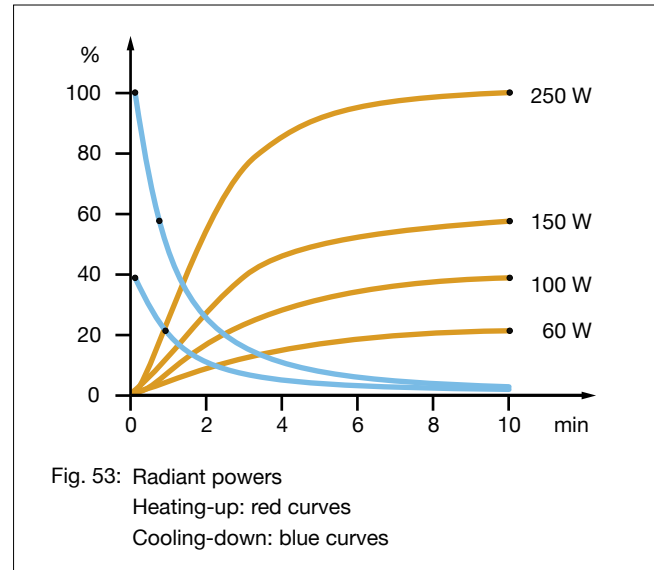
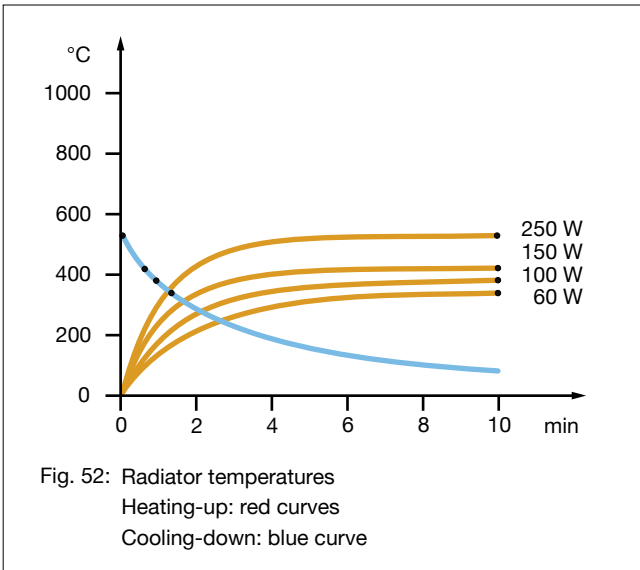

Figure: 51 Mounting dimensions and radiator dimensions () in mm



Type, weight, wattage	IOT/75	85 g	60	100	-	-	W
	IOT/90	140 g	-	-	150	250	W
Surface rating			8.6	14.4	15.0	25.0	kW/m ²
Typical operating temperature			290	380	420	490	°C
Maximum permissible temperature			530	530	530	530	°C
Wavelength range			3 - 10				µm

Standard design Operating voltage 230 V Ceramic hollow casting E27 Edison screw cap	Thermocouple radiators Not available. For means of controlling output see below.	Variants Special wattages Special voltages
---	---	---

The power can be adjusted using proprietary power controllers or dimmers.

Porcelain or metal sockets with porcelain inserts are to be used both for electrical and mechanical connection of Elstein IOT/75 and IOT/90 radiators. The sockets must not contain any plastic components.

The national safety regulations must be complied with for the respective application, for example, the IEC or EN standard 60519-1, Safety in electrical heating installations and VDE 0700 Part 71 or EN 60335-2-71, Regulations for Electrical heaters in animal breeding and keeping of livestock.

Further information is given in the safety information enclosed with each radiator.



Figure 54: Elstein BSH construction panel 375 x 750 mm with HSR

The BSH construction panel system was developed for optimum use of Elstein's HTS and HSR ceramic panel radiators.

Elstein BSH construction panels are infrared radiation areas being factory assembled. The ceramic infrared panel radiators are fixed to the MBO mounting sheets and surrounded with a frame section made from extruded aluminium alloy and stainless steel capping sections.

The user only has to do the wiring, insert the BSH panel in a steel section frame to be made on site and connect the panel with the electricity mains.

The BSH system is ideal for heating all types of goods with a large area and can be installed in any position.

Elstein BSH construction panels are available in dimensions from 125 x 250 mm up to 1000 x 1500 mm and can be fitted with radiators with wattages up to 600 W.

Length in mm

Inner dim. (Outer dim.) [No. of rad.]	250 (307) [2]	375 (432) [3]	500 (557) [4]	625 (682) [5]	750 (807) [6]	875 (932) [7]	1000 (1057) [8]	1125 (1182) [9]	1250 (1307) [10]	1375 (1432) [11]	1500 (1557) [12]		Radiator wattage
125 (182) [1]	0.50	0.75	1.00	1.25	1.50	1.75	2.00	2.25	2.50	2.75	3.00	kW	250 W
	0.80	1.20	1.60	2.00	2.40	2.80	3.20	3.60	4.00	4.40	4.80	kW	400 W
	1.20	1.80	2.40	3.00	3.60	4.20	4.80	5.40	6.00	6.60	7.20	kW	600 W
250 (307) [2]	1.00	1.50	2.00	2.50	3.00	3.50	4.00	4.50	5.00	5.50	6.00	kW	250 W
	1.60	2.40	3.20	4.00	4.80	5.60	6.40	7.20	8.00	8.80	9.60	kW	400 W
	2.40	3.60	4.80	6.00	7.20	8.40	9.60	10.80	12.00	13.20	14.40	kW	600 W
375 (432) [3]	1.50	2.25	3.00	3.75	4.50	5.25	6.00	6.75	7.50	8.25	9.00	kW	250 W
	2.40	3.60	4.80	6.00	7.20	8.40	9.60	10.80	12.00	13.20	14.40	kW	400 W
	3.60	5.40	7.20	9.00	10.80	12.60	14.40	16.20	18.00	19.80	21.60	kW	600 W
500 (557) [4]	2.00	3.00	4.00	5.00	6.00	7.00	8.00	9.00	10.00	11.00	12.00	kW	250 W
	3.20	4.80	6.40	8.00	9.60	11.20	12.80	14.40	16.00	17.60	19.20	kW	400 W
	4.80	7.20	9.60	12.00	14.40	16.80	19.20	21.60	24.00	26.40	28.80	kW	600 W
625 (682) [5]	2.50	3.75	5.00	6.25	7.50	8.75	10.00	11.25	12.50	13.75	15.00	kW	250 W
	4.00	6.00	8.00	10.00	12.00	14.00	16.00	18.00	20.00	22.00	24.00	kW	400 W
	6.00	9.00	12.00	15.00	18.00	21.00	24.00	27.00	30.00	33.00	36.00	kW	600 W
750 (807) [6]	3.00	4.50	6.00	7.50	9.00	10.50	12.00	13.50	15.00	16.50	18.00	kW	250 W
	4.80	7.20	9.60	12.00	14.40	16.80	19.20	21.60	24.00	26.40	28.80	kW	400 W
	7.20	10.80	14.40	18.00	21.60	25.20	28.80	32.40	36.00	39.60	43.20	kW	600 W
875 (932) [7]	3.50	5.25	7.00	8.75	10.50	12.25	14.00	15.75	17.50	19.25	21.00	kW	250 W
	5.60	8.40	11.20	14.00	16.80	19.60	22.40	25.20	28.00	30.80	33.60	kW	400 W
	8.40	12.60	16.80	21.00	25.20	29.40	33.60	37.80	42.00	46.20	50.40	kW	600 W
1000 (1057) [8]	4.00	6.00	8.00	10.00	12.00	14.00	16.00	18.00	20.00	22.00	24.00	kW	250 W
	6.40	9.60	12.80	16.00	19.20	22.40	25.60	28.80	32.00	35.20	38.40	kW	400 W
	9.60	14.40	19.20	24.00	28.80	33.60	38.40	43.20	48.00	52.80	57.60	kW	600 W

Maximum surface rating 38.4 kW/m²

Weight approx. 48 kg/m²

Larger dimensions and surface ratings available on request

Figure 55: Overview of the standard dimensions, outer dimensions (), number of radiators [] and the connected loads in kW

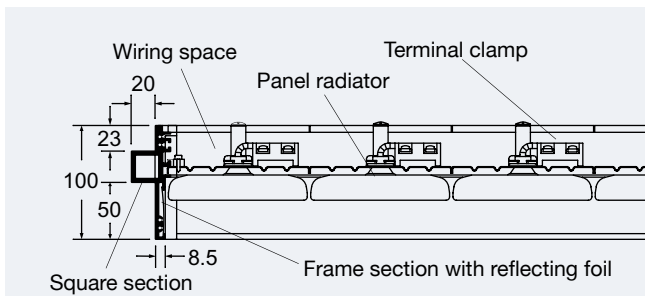

Fig. 56: Structural design of the BSH construction panel



Fig. 57: Wiring space of a BSH construction panel

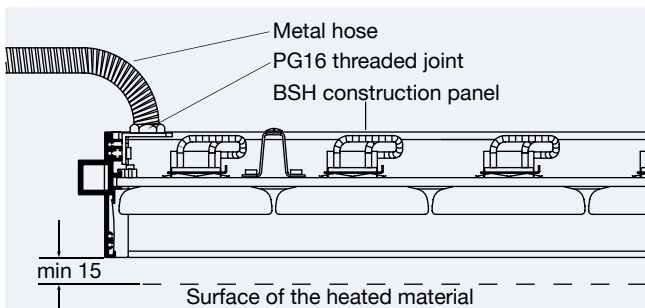

Fig. 58: Arrangement of the connection unit for establishing the mains connection



Fig. 59: BSH construction panel, inserted in a steel section frame

Standard scope of delivery (variants available on request)

Ceramic infrared radiators HSR or HTS, T-HTS, fitted

Radiators can be chosen from the radiator power levels 250 W, 400 W and 600 W. Mixed radiator wattages can also be fitted. One thermocouple radiator is provided for each construction panel equipped with HTS.

Extruded AL-frame sections with AL-square section and capping sections made from stainless steel, fitted

These components are used to surround the ceramic infrared radiators fixed to the MBO mounting sheets. The square section with a side upstand enables the BSH construction panels to be hung into a steel section frame to be built on site.

AK bipolar terminal clamps, fitted and connected with radiator power leads

For the electrical wiring of the individual radiators in connection with heat resistant insulated nickel wires and connection of the thermocouple radiator with the heat resistant insulated thermo line.

Mounting units, enclosed, individual parts are not fitted

A mounting unit contains an angle section, up to 3 heat resistant flexible metal hoses 1m long and PG 16 and other screw fitting accessories. The hoses are used to hold the nickel wire and thermo line and to protect them from mechanical stress. The mounting units can be fixed to anywhere on the BSH frame section.

Wiring material (nickel wire, thermo line), enclosed

Nickel wire (2.5 mm², max. 500 °C, max. 11 A) is supplied for the electrical wiring of the ceramic infrared radiators. The thermo line (1 mm², max. 400 °C) is used to connect the thermocouple to the controller. The Elstein product range includes a compensating line (1 mm², max. 100 °C) for extending this connection outside the IR radiation area.

Further information and safety information are given in the technical explanations of this brochure. The BSH mounting instruction also includes safety information as well as further details about the installation and the electrical connection.



Figure 60: Elstein EBF equipped with radiators of the HTS series

Elstein EBF construction elements are assembled in our factory. They can be equipped with Elstein ceramic panel radiators FSR, HSR/1, HTS/1, SHTS/1 and FSR/2, HSR/2, HTS/2, SHTS/2, whereby it is also possible to combine different radiator designs and wattages of the same types of radiators.

The ceramic infrared radiators mounted in stainless steel reflectors are inserted in the lower part of an extruded, anodised aluminium section with an H-shaped cross-section. Aluminium capping sections close the wiring space in the upper part of the section and die cast end pieces close the end faces.

The user only has to do the wiring, screw in the EBF elements in a steel section frame to be made on site and connect up with the electricity mains.

Elstein EBF construction elements are available in four lengths and can be fitted together to form flat or curved radiation panels in any installed position.

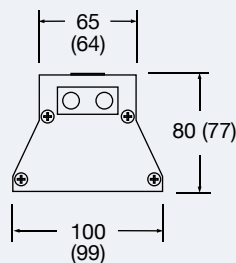
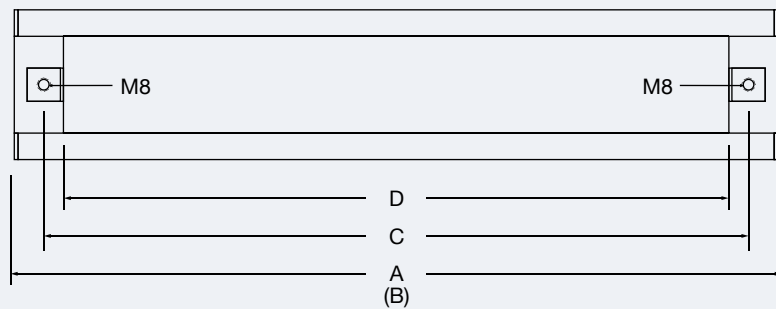

	A	B	C	D
EBF/25	260	255	217	190
EBF/50	510	505	467	440
EBF/75	760	755	717	690
EBF/100	1010	1005	967	940

Figure 61: Mounting dimensions and EBF dimensions () in mm

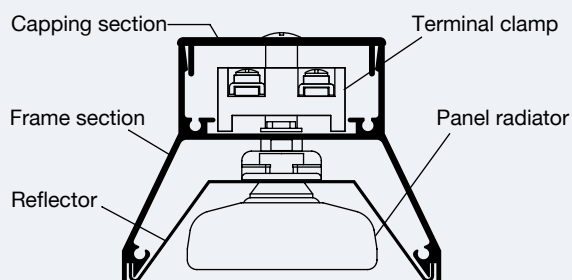

Fig. 62: Cross-section through an EBF construction element



Fig. 63: Wiring space of an EBF construction element



Fig. 64: Four examples of radiator equipment for an EBF/100 construction element



Fig. 65: EBF construction element, screwed onto a steel section frame

Standard scope of delivery (variants and other lengths are available on request)

Ceramic infrared radiators (FSR, HSR/1, HTS/1, SHTS/1, FSR/2, HSR/2, HTS/2, SHTS/2), fitted

The maximum radiator power level available is 1200 W. Mixed radiator wattages and dimensions can be fitted.

Thermocouple radiators for temperature control are installed in the EBF construction element at the request of the customer. Accessories for controlling the temperature, such as the TRD temperature controller and TSE thyristor switching units are included in the Elstein range of products.

REO reflectors for the radiator dimensions 245 mm x 60 mm and 122 mm x 60 mm, fitted

The REO reflectors are made from polished stainless steel. They are used for holding and fixing the radiators and reflecting the IR radiation in the direction of the material to be heated. On request, the reflectors fitted with ceramic infrared radiators are also available separately under the type designations REF/250 and REF/125.

Extruded frame and capping sections and die cast end pieces made from aluminium, fitted

For surrounding the ceramic infrared radiators fixed to the REO reflectors. Each EBF construction element includes a capping section and two end pieces. The end pieces have an M8 thread for screwing the EBF construction element with a steel section frame. The end pieces also include a ceramic bushing for the electricity cables and a labelled safety earth terminal.

AK bipolar terminal clamps, fitted and connected with radiator power leads

For wiring the ceramic infrared radiators. The Elstein range of products includes accessories for the wiring.

Further information and safety information are given in the technical explanations of this brochure. The EBF mounting instruction also include safety information as well as further details about the installation and the electrical connection.



Figure 66: Elstein REF construction sets with SHTS series radiators

By quoting the REF/250 or REF/125 construction set designations and the radiator type required, the REO/250 and REO/125 reflectors are available fitted with the FSR, HFS, HSR, HTS and SHTS series ceramic infrared panel radiators.

The REO reflectors are made from polished stainless steel. They are used to hold and fix panel radiators with the dimensions 245 mm x 60 mm (Figure 68) and 122 mm x 60 mm (Figure 69) as well as for reflecting the IR radiation in the direction of the material to be heated.

The REF system can be used to assemble flat or curved IR radiation areas. As the electrical connections of the REF system are exposed, Elstein REF construction sets must be installed in closed heating areas or industrial ovens.

The Elstein range of products includes the EBF construction elements and the BSH construction panels as fitted heating area solution in which the electrical connections are situated in a housing.

REF/250

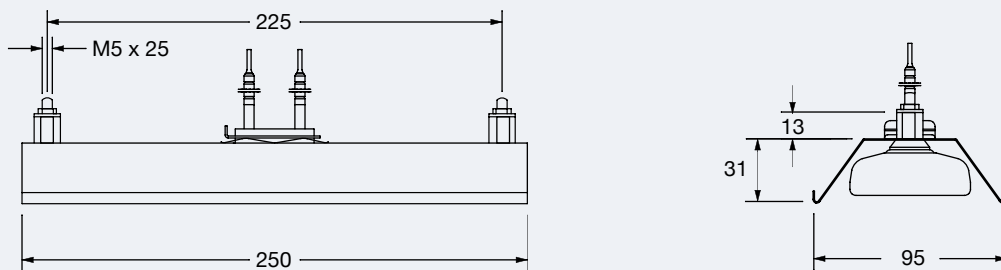

REF/125

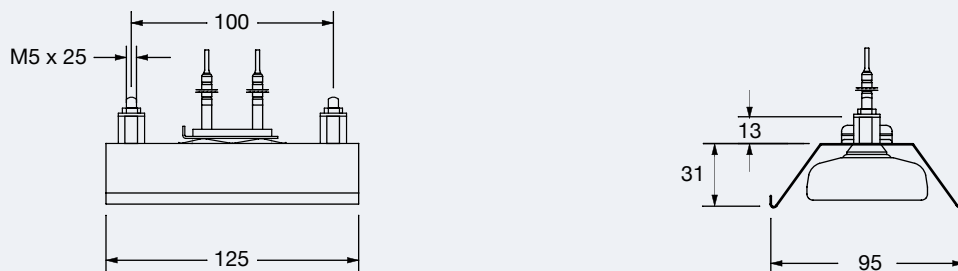

Figure 67: Mounting dimensions and REF dimensions () in mm



Fig. 68: Radiator types available for REF/250



Fig. 69: Radiator types available for REF/125

Reflector type, radiator type	REF/250, equipped with					
	FSR	HFS/1	HSR/1	HTS/1	SHTS/1	
	REF/125, equipped with					
	FSR/2	HFS/2	HSR/2	HTS/2	SHTS/2	
Maximum possible surface rating	40.0	24.0	40.0	40.0	48.0	kW/m ²
Maximum possible typical operating temperature	720	630	860	860	860	°C
Maximum permissible temperature	750	700	900	900	900	°C
Wavelength range	2 - 10					µm

Standard design	Thermocouple radiators	Variants
<p>Reflector made from polished stainless steel with two M5 x 20 fixing screws, spacer bolts and M5 nuts (fitted)</p> <p>Ceramic infrared radiator, fixed to the reflector</p>	<p>Available, except for HSR series radiators</p> <p>Designation REF/... with T-...</p> <p>for example: REF/250 with T-HTS/1 250 W 230 V</p>	<p>Special wattages</p> <p>Special voltages</p> <p>Extended leads</p> <p>Live leads with ring terminals</p>

The power can be controlled using thermocouple radiators together with TRD temperature controllers, TSE thyristor switching units and other accessories.

The national safety regulations must be complied with for the respective application, for example, the IEC or EN standard 60519-1, Safety in electrical heating installations.

Further information and safety information are given in the mounting instruction.

Connection and Control Accessories

1) Elstein TRD 1 temperature controller

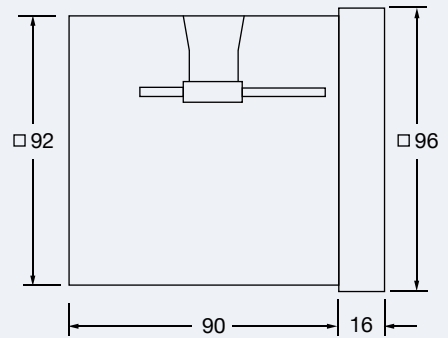

2) Elstein thyristor switching units



TSE 40 A



TSE 20 A

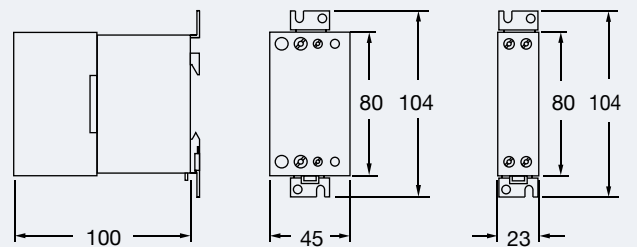

3) Elstein fuse holders



PST 14



PST 10

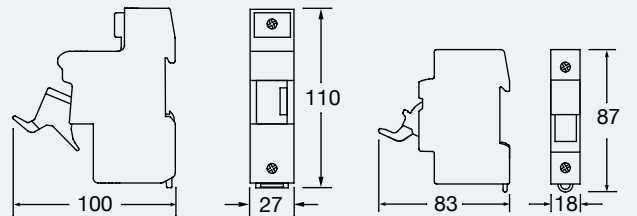

4) Elstein fuses



URG 50 A



URG 20 A

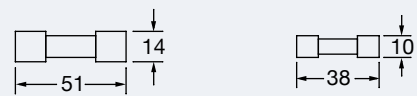

5) Elstein AK terminal clamp

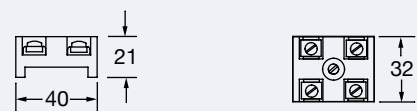

6) Elstein nickel wire

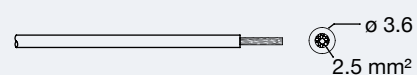

7) Elstein thermo line

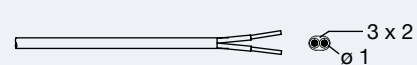

8) Elstein compensating line

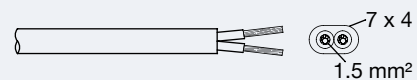

Figure 70: Electrical and temperature controlling accessories

Figure 71: Electrical and temperature controlling accessories, Dimensions in mm

Connection and Control Accessories

1) Elstein TRD 1 temperature controller

Type:	two point controller with PID performance
No. of switching units:	max. 6 TSE per controller
Temperature sensor:	NiCr-Ni + 16 further types
Control range:	up to 1100 °C
Setpoint setting:	in 1 °C steps, 4 setpoint values, distant access
Outputs:	2 x 0/12 V DC bi-stable load max. 30 mA and 2 relay outputs
Supply voltage:	95 V - 263 V, 48/63 Hz
Measuring circ. monit.:	outputs are switched off in case of break of sensor
Perm. ambient temp.:	0 - 55 °C
Perm. air humidity:	< 90%
Setpoint value display:	LCD 14.0 mm, green
Actual value display:	LCD 19.7 mm, red
Degree of protection:	front side IP 65 rear side IP 20
Connections:	screwed terminals
Installed position:	any
Dimensions:	DIN format 96 x 96 mm

The TRD 1 electronic temperature controllers analyse the signal of the thermocouple being integrated in each thermocouple radiator. The TRD 1 temperature controllers operate as quasi-continuous controllers and their factory settings are specially matched to the controlled process performance of Elstein infrared systems, so that practically no temperature fluctuations occur.

The two 0/12V DC logical outputs control the TSE thyristor switching units. In addition, two programmable floating relay contacts are available, which can be used, for example, as alarm contacts in conjunction with the limit comparators.

Further information and safety information are given in the TRD 1 operating instruction.

2) Elstein TSE thyristor switching units

The TSE thyristor switching units are used to switch the load circuits (infrared radiators) and are available in two power stages:

TSE 40 A, max. 40 A = 9.2 kW at 230 V
TSE 20 A, max. 20 A = 4.6 kW at 230 V

TSE thyristor switching units are supplied complete with heat sink and mounting clips for 35-mm standard rails. They are not subjected to any contact wear and therefore do not cause any switching

noises. They are easy to install and their service-life is virtually unlimited.

The loads are switched on at voltage zero and switched off at current zero. This means there is no system perturbation.

The permissible voltage is 24 - 265 V for TSE 20 A and 42 - 660 V for TSE 40 A. A thyristor switching unit must be provided for each phase of a multi-phase connection to a 230/400 V alternating current mains.

The thyristor switching units must be protected against short circuits with super-agile fuses.

Transformers cannot be switched due to the Rush Effect.

Further information and safety information are given in the TSE 1 operating instruction.

3) Elstein PST 14 fuse holder for URG 50 and PST 10 fuse holder for URG 20

The fuse holders can be clipped onto 35-mm standard rails and make a disconnection from the voltage possible according to the technical rules for safety. When changing the fuses, the front lever only has to be pressed down to expose the fuse shaft.

4) Elstein URG 50 A fuse for TSE 40 A and URG 20 A fuse for TSE 20 A

The super-agile fuses are used to protect the thyristor switching units against short circuits. Conventional fuses are unsuitable.

5) Elstein AK terminal clamp, 2-pole, consisting of steatite socket and stainless steel metal parts for cables with a maximum wire cross-section of 2.5 mm.

6) Elstein nickel wire, max. 500 °C, max. 11 A, single core, 2.5 mm² wire diameter, for the electrical connection of the ceramic infrared radiators.

7) Elstein thermo line, NiCr-Ni, max. 400 °C, for connecting the thermocouple integrated in the thermocouple radiator with the temperature controller.

8) Elstein compensating line, NiCr-Ni, max. 100 °C, for extending the connection thermocouple-controller outside the IR radiation area.

Metal Parts

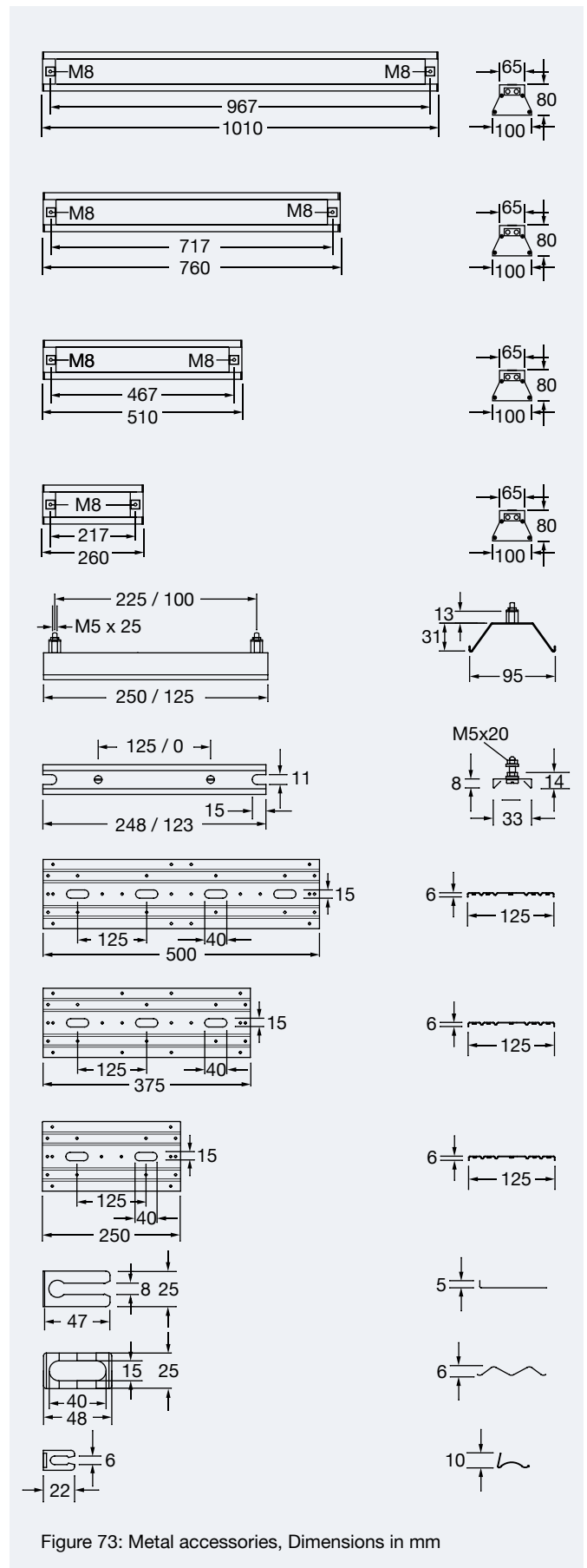

1) Elstein EBO housings

The EBO housings consist of an anodised, extruded aluminium section with an H-like cross-section, on which an aluminium capping section and two aluminium die cast end pieces are fitted.

Each die cast end piece contains a sliding nut with M8 thread for fixing the housings, for example on a steel section frame. They also contain a ceramic bushing for the electricity cables and a labelled safety earth terminal.

The EBO housings are available in the lengths 250 mm, 500 mm, 750 mm and 1000 mm. Other sizes beginning from 125 mm length are also possible.

EBO housings being equipped with Elstein radiators are available as ready-for-assembly construction elements by using the designation EBF (see there).

2) Elstein REO reflectors

The REO/250 and REO/125 reflectors are used to hold and fix the FSR, HFS/1, HSR/1, HTS/1, SHTS/1, and FSR/2, HFS/2, HSR/2, HTS/2 and SHTS/2 ceramic infrared radiators, and to reflect the IR radiation in the direction of the material to be heated.

They are made from polished stainless steel and have a protective foil on the inside which must be removed before installation.

REO reflectors are part of the ready to fit EBF construction elements and the fitted REF construction sets.

They are available in the two lengths 125 mm and 250 mm.

3) Elstein MPO mounting profiles

The MPO mounting profiles are made from stainless steel and are used to hold and fix HLS and IRS series radiators.

They are available in the two lengths 125 mm and 250 mm.

4) Elstein MBO mounting sheets

The MBO mounting sheets are designed for holding and fixing ceramic infrared radiators with

the dimensions 122 mm x 122 mm.

They are made from stainless steel and have a protective foil on the upper side which must be removed before installation.

MBO mounting sheets are part of the ready to fit BSH construction panels and are available in the lengths 250 mm, 375 mm and 500 mm.

5) Elstein mounting set

All ceramic infrared radiators, which have a standard Elstein socket are fixed to the reflector or mounting sheet with the help of the mounting set.

The mounting set includes a wave mounting spring and a slide, both made from stainless steel.

The scope of delivery of the radiators with a standard Elstein socket includes one mounting set for each radiator.

6) Elstein fixing springs

The fixing springs are made from stainless steel and are used to fix HLS and IRS series radiators to the MPO and MPO/2 mounting profiles.

Two springs per radiator are included in the scope of supply of HLS and IRS series radiators.

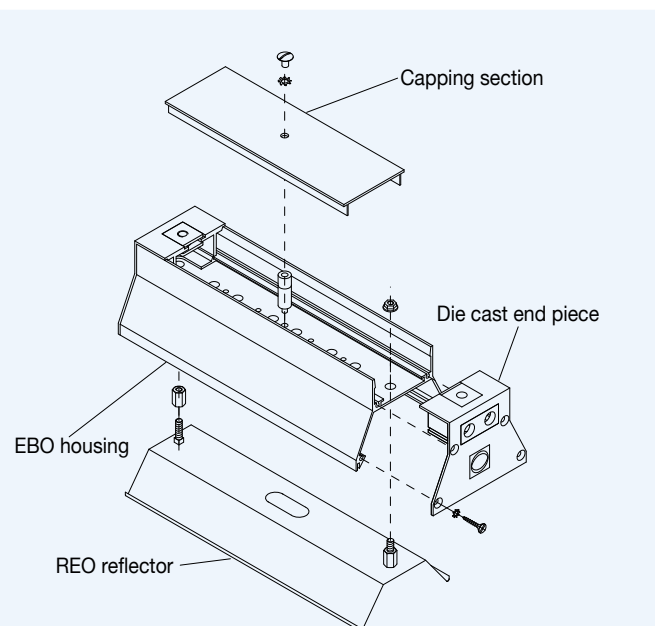

Figure 74: Example for the arrangement of metal parts using an EBO housing with REO reflector

Radiation Distribution

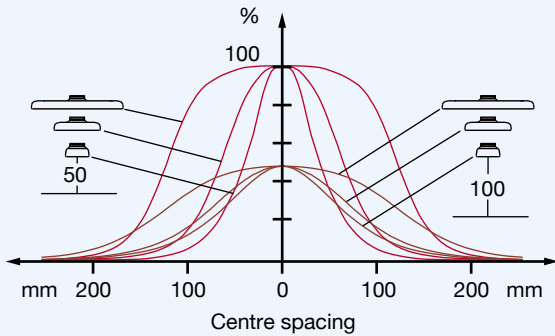

Figure 75: Spatial radiation distribution

Elstein infrared radiators are produced with all kinds of different dimensions. They are available with round, long, square, rectangular and even with hemi-sphere shapes. The spatial distribution of the diffuse energy radiated in all directions depends on the outer shape. Figure 75 shows the radiation distributions for 2 spacings of an Elstein HTS. Similar distributions also result for the other models. The intensity is determined by the respective surface temperature. At this point, please note that the curved shape of the FSR does not have any focussing effect with respect to the radiation.

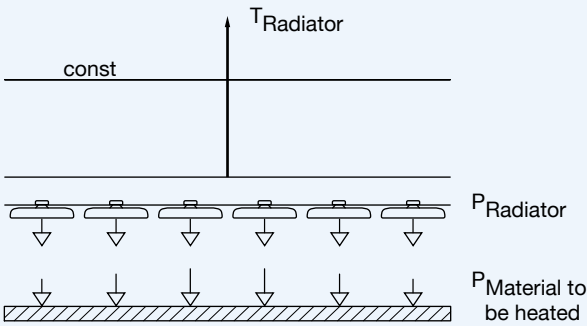

Figure 76: Power at the material to be heated with constant radiator power

In plants with a large number of radiators, the radiation distributions of all the radiators overlap. If, for example, several radiators with the same power output are installed next to each other in a machine, there is an increase in power in the middle of the material to be heated which is mostly unwanted (Figure 76). For uniform power density on the material to be heated, the radiators near the edge must be run with higher power or a higher temperature than the middle radiators (Figure 77).

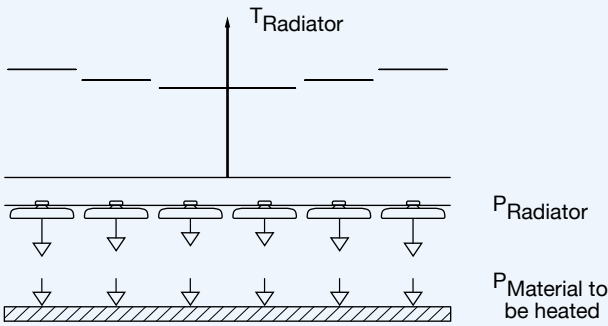

Figure 77: Power at the material to be heated with adjusted radiator power

The small design of Elstein infrared radiators enables the user to realise very different radiation distributions on the material to be heated. As radiation energy occurring at a point is the sum of the energy from all the radiators it is sometimes difficult to radiate narrow areas with a particularly intensive or weak radiation. In these cases considerable improvements can be achieved by using shiny metallic reflector plates or shutters. Figure 78 shows examples of possible designs.

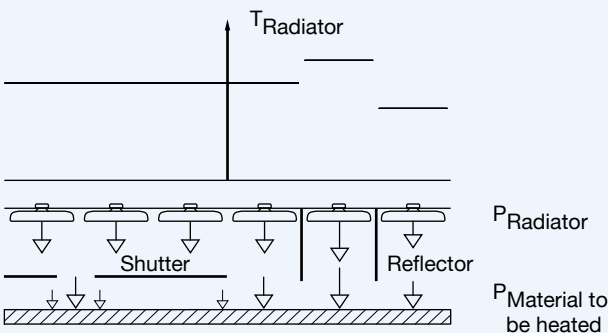

Figure 78: Power adjustment with reflector and shutter

One question often asked is whether additional thermal insulation is needed behind the radiators. This thermal insulation only has a useful effect if the requirements for the uniformity of the radiation distribution on the material to be heated are low. The thermal insulation causes heating of the inner radiators by the outer radiators of a heating area. In the most unfavourable case, the inner radiators can even become superfluous. The majority of the radiation areas are therefore not insulated. In addition, the modern HTS, SHTS and HSR series radiators already have integrated thermal insulation, which does not usually require any additional insulation.

Power Adjustment

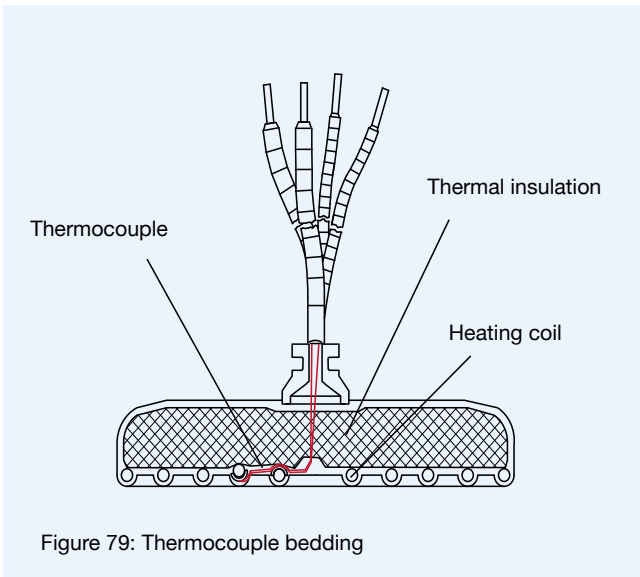

Figure 79: Thermocouple bedding

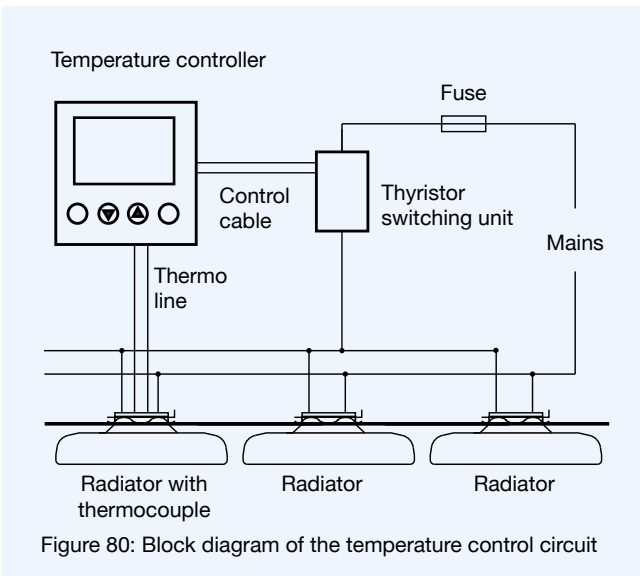

Figure 80: Block diagram of the temperature control circuit

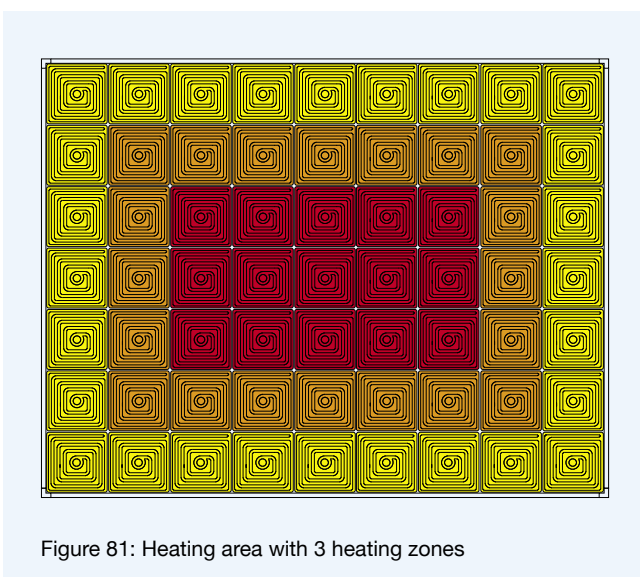

Figure 81: Heating area with 3 heating zones

Elstein infrared radiators are available with varying power levels. The HTS for example has power levels ranging from 250 W to 1000 W. In practice however powers different to these are mostly required. There are three ways of adjusting the radiator power to the power requirements of the material to be heated. The most simple way is to change the distance between the radiator and the material to be heated. This is only recommended if individual radiators are used. The second way is power control, for example using proprietary dimmers, like those used for lighting purposes.

The third and best way is to adjust the power via temperature control using radiators with an integrated thermocouple. In Elstein's infrared radiators with thermocouple, the thermocouple is located between the radiator surface and the heating coil (Figure 79).

The thermocouple signal is passed via a special thermo line, for example to the input of the Elstein TRD 1 digital temperature controller (Figure 80). The temperature controller switches individual or whole groups of radiators on and off with the help of one or several Elstein TSE thyristor switching units. An average power sets in at the radiators, depending on the length of time they are switched on. A super-agile fuse is fitted upstream of the thyristor switching units to protect them against short circuits.

This method enables compliance with the prescribed radiator temperature with an accuracy of one degree and thus enables the production conditions to be reproduced. It can also be modified so that the temperature of the material to be heated is measured. However, this requires reliable recording of the temperature of the material to be heated. In most cases it suffices to control the radiator temperature.

By using several controllers, zones can be formed in the heating areas, for example, to specifically heat certain areas of the product more strongly or weakly. Annular heating zones are frequently realised for large heating areas in order to uniformly heat up the material to be heated from the boundary area through to the middle (Figure 81).

Special programmable controls can also be used instead of a controller. Here it must be noted that the inputs for the thermocouples must be floating.

Performance

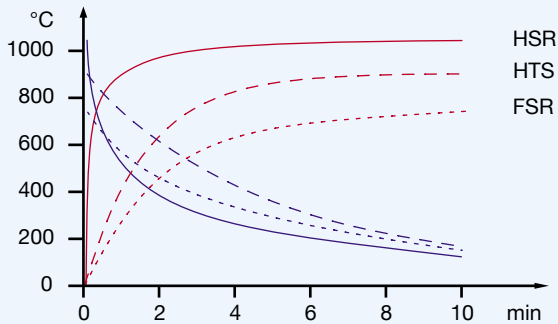

Figure 82: Heating-up and cooling performance

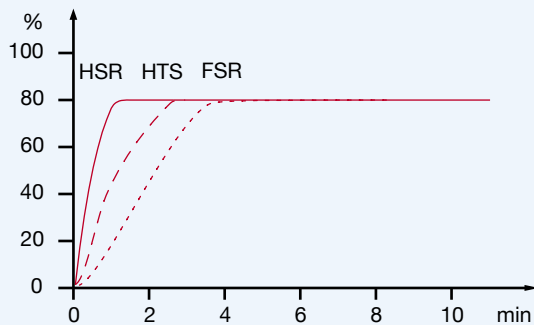

Figure 83: Power in controlled operation

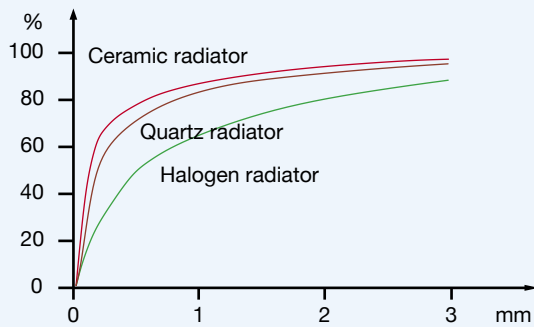

Figure 84: Absorption in transparent foils

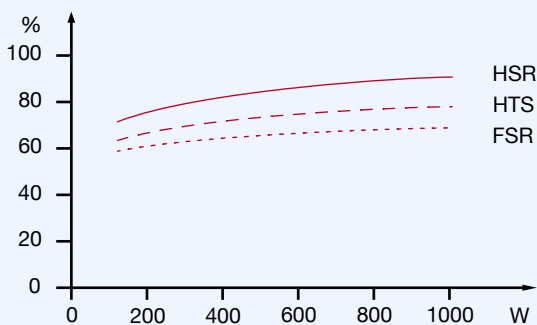

Figure 85: Efficiencies dependent on the power

Elstein infrared radiators differ in their mechanical structure. For example, the HTS series radiators have integrated thermal insulation materials, so that compared to the FSR series radiators, considerably reduced heating-up and cooling times are achieved (Figure 82). With the HSR series radiators the time performance was improved again by a factor of 3. Even if stationary heating tasks are to be solved mostly, fast heating up reduces the time taken before work can be started (Figure 83). Short cooling times are also advantageous in case of faults.

In this context, please note that the heating-up and cooling performance of an infrared radiator can be more easily judged with the heat sensitivity of the skin rather than with the eye. For example, if a halogen spotlight is switched off, the light goes off in a flash. But the hot glass tube continues to dissipate its stored heat to surrounding area for several minutes in the form of infrared radiation.

Infrared heating occurs close to the surface. The infrared radiation only penetrates transparent goods. Figure 84 shows this for 3 radiation sources for heating a foil. The more long-waved the radiation the more energy is absorbed near the surface. However, it should be noted that even the slightest additives harmonises the heating up performance in the direction of the ceramic radiator. If radiation can penetrate a material the absorption is poor, which in turn is reflected in the efficiency of a plant.

The efficiency of Elstein infrared radiators can reach values over 80 % in radiation areas. Figure 85 shows the typical curves for various panel radiators. You can see that the HTS and FSR radiators achieve very good efficiency values even at lower radiator powers. The HTS is clearly better than the FSR, thanks to its internal thermal insulation. The best efficiencies are achieved by the HSR radiators, as they dissipate little heat to the rear.

When using Elstein infrared radiators, the limit temperatures given on each radiator must be noted and observed. If it is exceeded, the ceramic and heating wire can be damaged. Equally, when installing the radiators ensure that the radiators are protected against knocks, impact, and moisture when cold. Due to the fixed installation of the heating coil, the radiators can be operated in any position.

Planning Guidelines

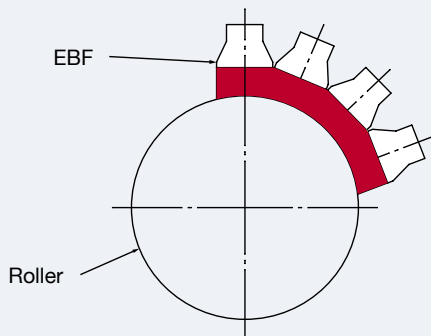

Figure 86: Roller heating using the EBF system

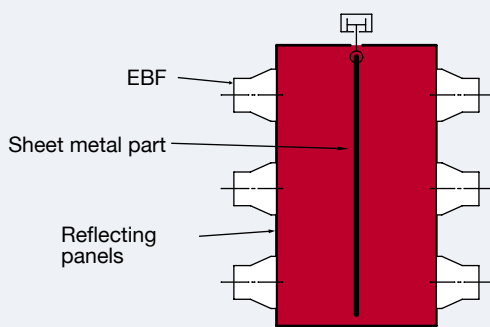

Figure 87: Radiation tunnel with several EBF systems

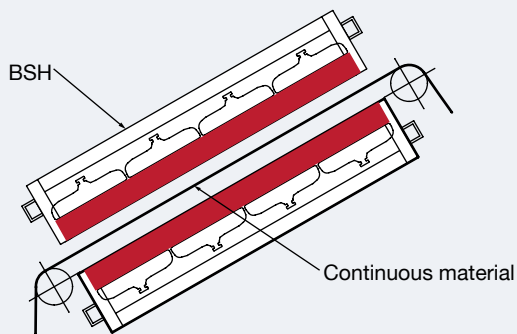

Figure 88: Heating a continuous material using 2 BSH systems

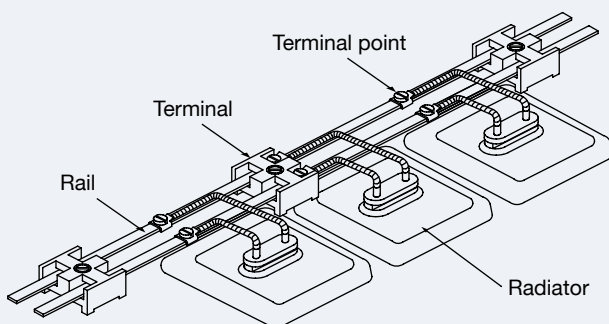

Figure 89: Rail wiring

When planning an infrared heating plant or system, it is the properties of the material to be heated which primarily determine the power and treatment time required. The easiest and most reliable way to determine the data concerned is to carry out a trial. We are always pleased to provide planning advice and if you wish can carry out heating trials for you.

The choice of radiator initially depends on the geometric circumstances of the heating task. The HTS series is the best choice for the radiator type. The integrated thermal insulation, the fast thermal performance and the ability to adjust the power via integrated thermocouples offer users optimum possibilities. If fast clock times or high material temperatures are required, the HSR and HLS series can be used. If a low overall height is required, FSF radiators can be used.

For systems, the choice is between BSH, EBF and REF. The EBF system is particularly advantageous for solving line-shaped or curved heating tasks and for individual applications. The BSH system on the other hand is ideal for heating goods with a large area. All systems can be used with both a one-sided and a double-sided arrangement. If two heating areas radiate each other, for safety reasons special attention must be paid to compliance with the maximum permissible radiator temperatures.

In operation, the EBF and the BSH system can reach housing temperatures of up to around 250 °C. Therefore, the user must plan in design measures to prevent contact with the hot metal parts. Elstein infrared radiators do not have any dazzling effects. However we recommend screening off the sides of the heating areas with polished aluminium or stainless steel plates. This prevents unnecessary heating of parts outside the actual oven and improves energy utilisation. For stability reasons, EBF and BSH systems must not have any additional thermal insulation.

When designing the industrial ovens, particular attention must be paid to ensuring all parts can thermally expand. Large, stiff constructions are therefore disadvantageous. In this context the wiring material is also important. Copper cables can only be used for individual radiators with a low power. The standard are cables made from nickel with heat resistant insulation or rail wiring.

General Information

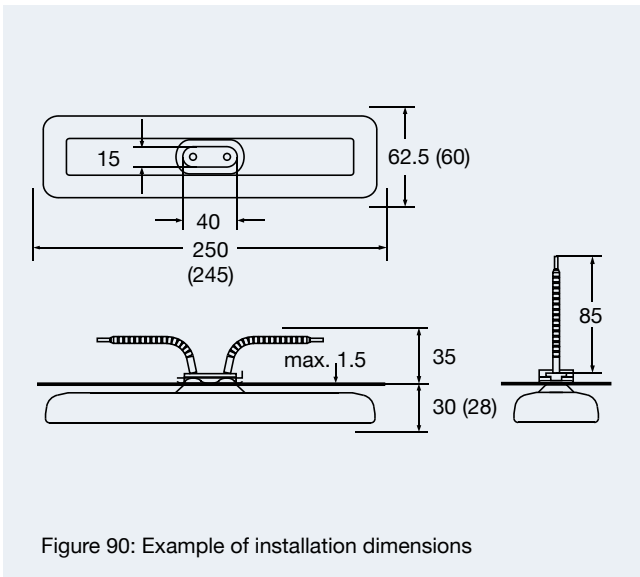

Figure 90: Example of installation dimensions

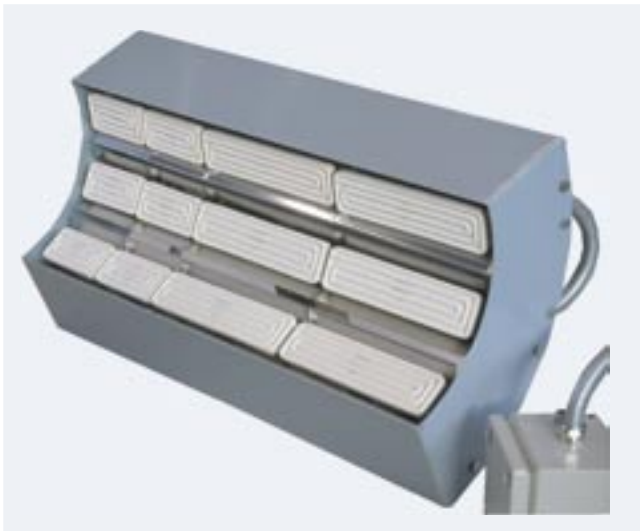

Figure 91: Roller heating

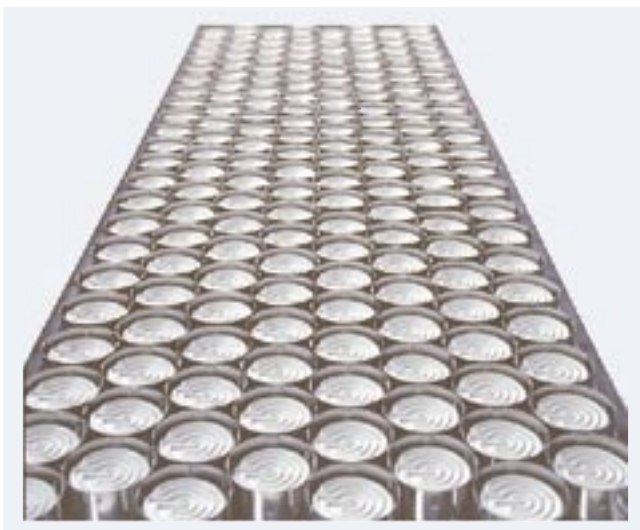

Figure 92: Heating area to heat up the bottoms of bottles

Due to the thermal expansion, when designing plant or systems you must ensure that the infrared radiators have adequate space. In general, a distance of 3 mm should be available between adjacent infrared radiators (Figure 90). The installed dimensions to be observed are given in the data sheets for Elstein infrared radiators.

The data sheets and the radiators themselves also list the limit temperatures to be observed. Exceeding these temperatures by a considerable amount can damage the ceramic.

A frequently asked question concerns the service life or longevity of Elstein infrared radiators. We only use raw materials and heat conducting materials of a particularly high quality to manufacture our products. All radiators are also subjected to permanent quality assurance. However, as the durability of an infrared radiator decisively depends on its use conditions, we are unable to give individual values.

The durability is primarily influenced by the temperatures reached during use. For example, an HLS at 1100 °C in continuous operation has an average service life of 2000 hours. An SHTS with 900 °C on the other hand reaches about 8000 hours. Radiators with a low power often reach more than double this useful life. On the other hand, there are applications in which the radiators can fail after 1000 hours due to materials, which attack the heating coil or the ceramic. Such materials are, for example, chlorine, fluorine, hydrofluoric acid, sodium hydroxide, nitrogen and peroxide.

Except for under atmospheric conditions, Elstein infrared radiators are also used in vacuums. They are however not available in an explosion-proof version. Nevertheless, there are ways to reach solutions which enable Elstein infrared radiators to be used. We will be pleased to advise you if you have corresponding heating tasks.

As a standard Elstein infrared radiators are designed for 230 V. Sometimes however, customers want or need to use other operating voltages. Most Elstein infrared radiators can also be supplied with other voltages. Operating voltages above 270 V, however require thinner heating wires than usual. The consequence is a lower durability under the same operating conditions.

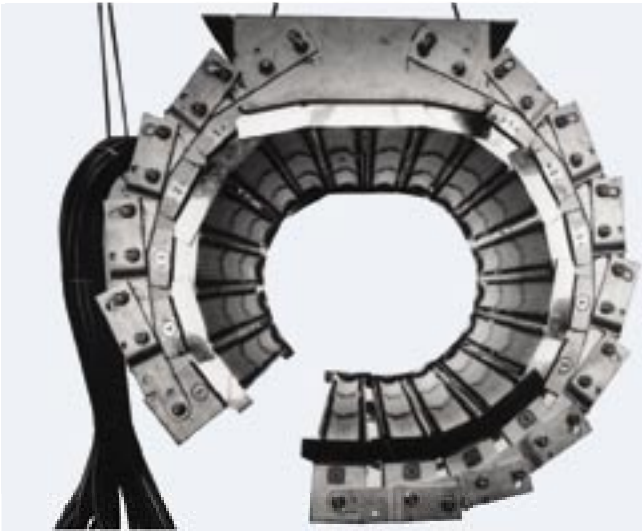

Figure 93: Heating head for heating GRP pipes



Figure 94: Heat therapy appliance

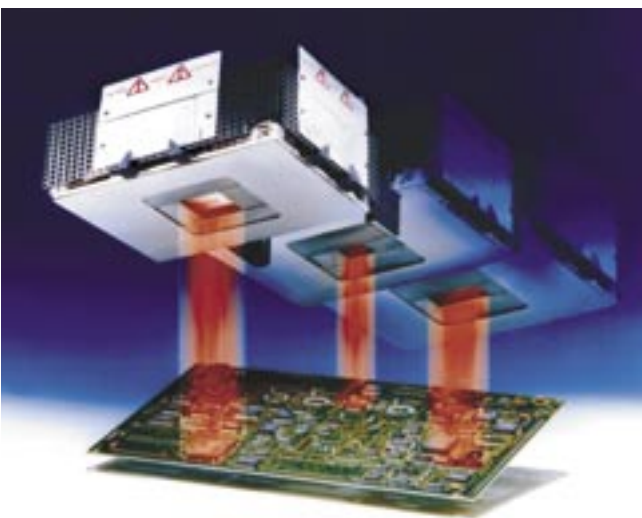

Figure 95: SMD soldering head for printed circuit board repairs

For decades, Elstein infrared radiators have been proven heating elements for solving heating tasks. They are available in various forms and power levels and therefore enable users, to optimally adjust to their heating task.

Elstein infrared radiators have the following advantages:

1. High emission capacity
2. Robustness
3. Long durability
4. Simple to control with degree accuracy
5. High surface rating up to 87 kW/m²
6. Standardised dimensions and powers
7. Modular structure
8. Scale free surfaces.

These advantages have helped to guarantee customer satisfaction over decades and guarantee this in future tasks too.

The information given in this brochure of course only represents the core of our experience. Please contact us if you require further help in solving your heating task.

We thank the companies D. Krieger/Mönchengladbach, Rewatronik/Wald-Michelbach, Technova/Paris and Depke/Lübeck for kindly providing us with photos of applications.

Reprints and copies not permitted, even as extracts. We reserve the right to make changes according to technical progress.



Elstein-Werk M. Steinmetz GmbH & Co. KG
Specialist Factory for Ceramic IR-Radiators
Stettiner Straße 14, 37154 Northeim
Germany

Tel.: +49 (0) 5551 983 - 0
Fax: +49 (0) 5551 983 - 61
E-Mail: info@elstein.com
Internet: www.elstein.com